



ACTIV CARE

ADJUSTABLE BED

USER MANUAL



TABLE OF CONTENTS

1.	Symbols Used In This Manual	5
2.	Introduction	6
3.	Safety Precautions	7
4.	Specifications & Inclusions	9
5.	Accessories	10
6.	Handset Operation	11
7.	Castor Operation	14
8.	Assembly Instructions	15
	8.1 Beds – How To Unpack & Install	
	8.2 Headboards – How To Assemble Or Mount	
	8.3 Accessories – How To Fit To Bed	
	8.4 Split King Upgrade Kit	
9.	Storage & Movement	28
10.	Cleaning	29
11.	Service & Maintenance	30
12.	Troubleshooting	31
13.	Warranty & Service	32
	13.1 Beds and Accessories	
	13.2 Mattresses	
14.	Service Log Book	35

© Copyright Aidacare Pty Ltd 2022 Version 1.0

No part of this user manual may be copied, distributed, reproduced, scanned or stored on any electronic database, whether in whole or in part in any form or by any means.

Due care has been taken to ensure all the information contained in this user manual is correct at the time of printing. All measurements, pictures, colours and weight capacities are to be used as a guide only. We reserve the right to modify the design or appearance of any product displayed in this user manual without prior notice.

1. SYMBOLS USED IN THIS MANUAL



WARNING

WARNING! Indicates a potentially hazardous condition/situation. Failure to follow designated procedures can cause either personal injury, component damage or malfunction. On the product, this icon is represented as a black symbol on a white triangle with a black border.



ALWAYS! These actions should be performed as specified. Failure to perform mandatory actions can cause personal injury and/or equipment damage. On the product, this icon is represented as a white infinity symbol on a black dot with a white border.

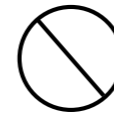

DO NOT! These actions are prohibited. These actions should not be performed at any time or in any circumstances. Performing a prohibited action can cause personal injury and/or equipment damage. On the product, this icon is represented as a white symbol with a black circle and black slash.

Thank you for choosing this Aspire ComfiMotion
ACTIV Care Adjustable Bed.

Our ComfiMotion Collection is designed to blend
seamlessly into the home environment,
whilst improving comfort and independence.

It is important that you read this user manual
carefully before using your new Adjustable Bed.



MAX USER WEIGHT

200kg

LONG SINGLE AND KING SINGLE

MAXIMUM PATIENT WEIGHT

This weight represents the total maximum weight of a patient on the bed. This weight (200kg) should not be exceeded at any time.



SWL FOR BED

250kg

SAFE WORKING LOAD (SWL)

This weight represents the total maximum weight that the bed can carry, including patient, mattress, bedding, bed ends and accessories. This weight (250kg) should not be exceeded at any time.



MAX USER WEIGHT

310kg max for
two people

LONG DOUBLE AND QUEEN

MAXIMUM PATIENT WEIGHT

This weight represents the total maximum weight of a single patient or two patients combined on the bed. This weight (310kg) should not be exceeded at any time.



SWL FOR BED

360kg

SAFE WORKING LOAD (SWL)

This weight represents the total maximum weight that the bed can carry, including patient(s), mattress, bedding, bed ends and accessories. This weight (360kg) should not be exceeded at any time.

2. INTRODUCTION

Aspire ComfiMotion Adjustable Beds are equipped with functions and features engineered to enhance user comfort, independence and safety. Designed for easy, multi-positional operation, cleaning and serviceability, this luxurious adjustable bed collection uses premium quality materials and finishes.

- **Floor line positioning** significantly reduces the risk of falls from a bed.
- **Night Assist:** Luminous underbed halo for safe entry and exit throughout the night.
- **Box-on-Box Design** facilitates easier entry and exit and allows true flush positioning of beds in companion or dual adjustable bed configurations.
- **Massage:** Relaxing vibration modes for personalised neck, shoulder and back relief.
- **USB Charge:** Connect and charge your devices conveniently.
- **Press and Hold Safety Handset:** Intuitive, large button interface enhances usability.
- **Enclosed Frame Design:** Ensures optimal positioning when getting into bed and safely covers the moving base platform.
- **Personalised Positioning:** Hand control allows users to find their perfect position to maximise comfort and relaxation.
- **Personalised Exit Height** allows a user to preset their bed exit height.
- **Battery backup** provides the user with confidence that the bed will still operate during a power outage.
- **Smart Descent** ensures user safety when lowering to floor by intermittently stopping and then slowing down for final descent.

3. SAFETY PRECAUTIONS

This User Manual outlines the intended use of an Aspire ComfiMotion Adjustable Bed. This constitutes how to achieve full functionality, whilst maximising the safety and efficiency of carers and users alike.

It is **important** that this User Manual is read in its entirety, prior to operating the bed. The manual is designed to ensure that users are equipped with all the information required to competently and responsibly operate the bed and its accessories.

It is recommended that the User Manual be kept in an easily accessible place for quick reference. If required Aidacare product specialists can provide additional training.

All warnings and cautions within this manual should be strictly adhered to. Failure to do so could result in harm to the carer or user.

Warnings highlighted throughout this manual identify possible hazards in procedures or conditions which if not followed correctly could result in serious injury, or fatality.

Cautions highlighted throughout this manual identify possible hazards in procedures or conditions, which if not followed correctly could result in equipment damage, or failure.

GENERAL

- Electrical equipment can be hazardous if used incorrectly.
- The clinically qualified person responsible should consider the age, size and condition of the patient before using the bed and its accessories.
- The maximum safe working load of the Bed is 250kg (Long Single & King Single) or 360kg (Long Double & Queen) and includes the mass of the patient, mattress and any accessories fitted to the bed.
- The maximum suggested standard mattress thickness for use with ComfiMotion Beds is 240mm.
- The bed should only be used with approved accessories. Contact Aidacare for a full list of approved accessories.
- If a patient's condition could lead to a possible entrapment the mattress support platform should be left in the flat position whilst unattended.
- To ensure safe functioning of the bed electronics, the electronic system must be reset when any changes are made to it.
 - Changes are defined as:
 - mains power is lost (power outage, turned off/on, mains cable is unplugged)
 - component cabling is disconnected from or connected to the control box or junction box
 - To complete the reset procedure, refer to step 13 in section 6.2 Handset Operation



ALWAYS position the bed at its lowest height when unattended to minimise the risk of patient injury from falls when getting in and out of the bed.



ALWAYS use a mattress of appropriate size and type. A range of suitable mattresses are also available from Aidacare.



ALWAYS make sure that the user is safely positioned to avoid entrapment before operating the bed.



ALWAYS ensure that carer and user limbs are free from potential entrapment areas before operating any functions.



ALWAYS apply the brakes (if castors installed) when the bed is stationary.



ALWAYS store the handset when not in use to avoid accidental operation of the bed's functions.



DO NOT use electrically operated beds in the presence of flammable gases.



DO NOT use accessories that are not designed, or approved for use with ComfiMotion Beds.

4. SPECIFICATIONS & INCLUSIONS

ACTIV CARE ADJUSTABLE BED

Please ensure you have familiarised yourself with the critical information below.

STANDARD INCLUSIONS:

x5



MATTRESS RETAINERS

4x Small (Side)

1x Long (Footend of Bed)

x1



HANDSET

See "Handset Operation" for usability instructions



	Overall Length x Width	Height Range	Recommended Mattress size (L X W X H)
Long Single BEB046740	2030 x 920mm	195-710mm	2030 x 920 x 200-240mm
King Single BEB046750	2030 x 1070mm		2030 x 1070 x 200-240mm
Long Double BEB046760	2030 x 1370mm		2030 x 1370 x 200-240mm
Queen BEB046770	2030 x 1520mm		2030 x 1520 x 200-240mm

	 Bed Weight	 Max User Weight	 SWL for Bed
Long Single	114 kg	200 kg	250 kg
King Single	126 kg		
Long Double	149 kg	310 kg	360 kg
Queen	156 kg		

5. ACCESSORIES

A range of ComfiMotion Bed accessories are available. In addition to the below listed accessories, Aidacare specialises in other complimentary products such as foam mattresses, pressure care surfaces, over bed tables, side lockers and adjustable day chairs. Please contact Customer Service on 1300 133 120 for further information.

Code	Description	Image
Long Single – BEA830120 King Single – BEA830130 Long Double – BEB830132 Queen – BEB830134 King – BEB830136	Allure Headboard	
Long Single – BEA830100 King Single – BEA830110 Long Double – BEB830112 Queen – BEB830114 King – BEB830116	Chesterfield Headboard	
BEA830211	Crook Handle Bed Stick	
BEA830212	Bed Rail	
BEA824200	Aspire ComfiMotion Transport Trolley	
BEA830230	Split King Upgrade Kit	
BEA830214	Simplified Handset	
BEA830213	Partner Handset (used with Long Double and Queen beds only)	



Do not use accessories that have not been designed for use with ComfiMotion Beds.

6. SETTING UP AND OPERATING THE HANDSET

PLEASE READ THE CRITICAL INFORMATION BELOW:



WARNING

- Ensure the user, carer and/or equipment is positioned to avoid being trapped or crushed during bed adjustment.
- Ensure the handset cord is not stretched excessively.
- Ensure the handset and electrical leads cannot become entangled with moving parts of the bed.
- **DISCONNECT** the power lead from the mains and stow before transporting the bed.
- If the power lead shows any sign of damage, replace immediately.

UNDERSTANDING THE RELEVANT HANDSET

ComfiMotion Beds are powered by five-to-six electric actuators, which are controlled by the Handset. Adjustment occurs only while a button is pressed. Adjustment will stop when the button is released, or the selection reaches the end of its range.

6.1 SETTING UP YOUR HANDSET(S)

NOTE: Handset cable is attached to control box out of factory; this guide is to assist if it becomes knocked or removed during assembly or if a replacement is needed.

1. Disconnect power to the bed by unplugging from wall socket
2. Disconnect the battery backup from the bed by disconnecting the below plug from the control box



3. Wait 10 seconds for all power to deplete from the control box
 4. Disconnect the existing handset(s) from the control box (if replacing) and attach your handset(s) to the ports shown overleaf
- NOTE:** only connect handsets in the configurations shown overleaf to avoid electronic system malfunction
5. Route the handset cable(s) carefully to the side of the bed that best suits the user/usage environment
 6. Reconnect the battery backup
 7. Reconnect power plug to wall socket
 8. Wait 10 seconds
 9. Conduct the Electronic System Reset procedure (see function 13 in section 6.2 Handset Operation) to ensure software is calibrated to the new handset

6.2 HANDSET OPERATION



LONG SINGLE AND KING SINGLE BEDS

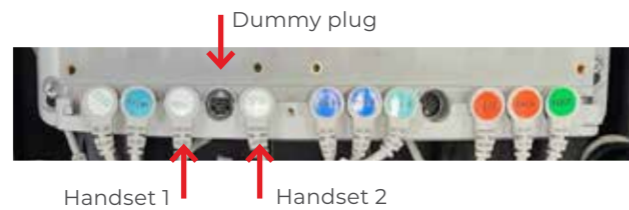

Either		
	Standard Handset GSP640220	Simplified Handset (Sold Separately) BEA830214

LONG DOUBLE AND QUEEN BEDS



			
	Standard Handset GSP640220	Partner Handset (Sold Separately) BEA830213	Simplified Handset (Sold Separately) BEA830214
Standard	x1		
Option 1	x1	x1	
Option 2	x1		x1
Option 3		x1	x1
Option 4			x2

STANDARD AND PARTNER HANDSETS

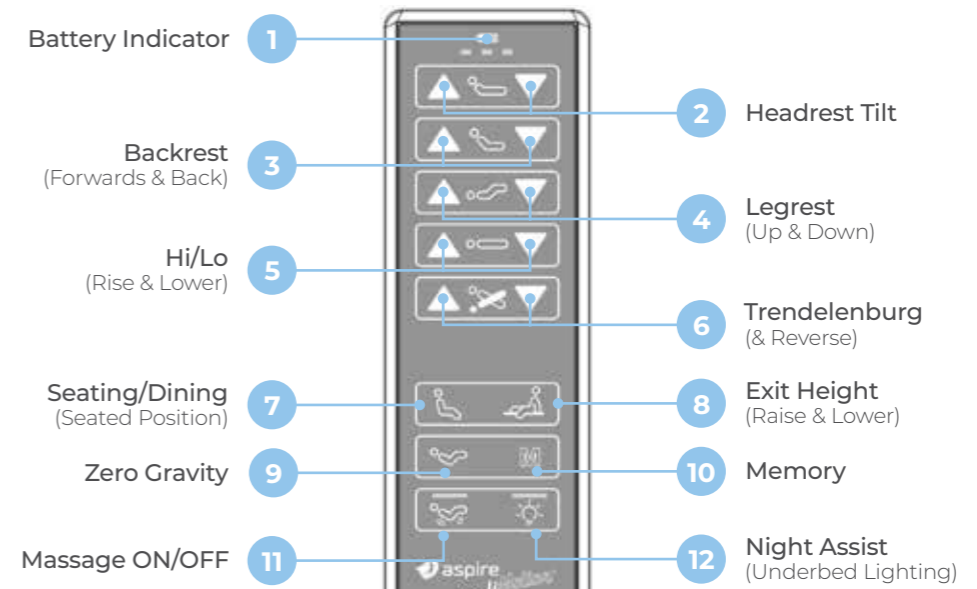

USING YOUR HANDSET



Press & Hold
to initiate function
Release
button to stop



WARNING

Extra care should be taken whilst operating the bed functions to ensure hands and fingers are free from potential squeeze hazards.

SIMPLIFIED HANDSET

(Sold separately)

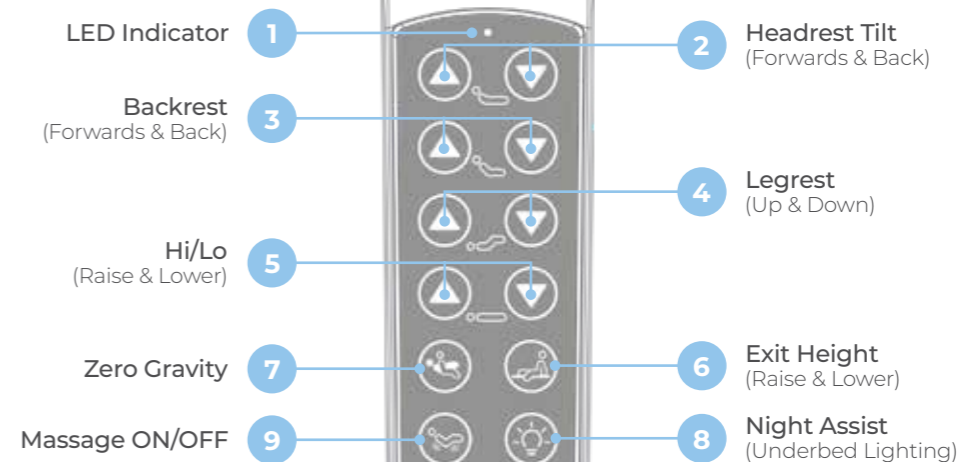

USING YOUR HANDSET



Press & Hold
to initiate function
Release
button to stop



WARNING

Extra care should be taken whilst operating the bed functions to ensure hands and fingers are free from potential squeeze hazards.

1	Battery Indicator (standard handset) LED Indicator (simplified handset)
2	Headrest Tilt: Adjusts the headrest between 65 – 85°. This can help alleviate neck muscle strain, providing optimal support while reading or watching TV.
3	Backrest: Adjust the backrest (up to 60°) providing postural support, easing symptoms of reflux, respiratory conditions, snoring and sleep apnoea.
4	Legrest: Adjust the legrest to promote better circulation, relieving tired, swollen and/or painful limbs.
5	Hi / Lo: Raise and lowers the height of the bed. Consider lowering the bed to assist with bed entry and exit. NOTE: The bed will intermittently stop during its descent to minimum height. Keep pressing down button to continue lowering bed.
6	Trendelenburg: (-14°) and Reverse (14°): This position helps facilitate blood pressure localisation as well as promote low cardiac output. This medically prescribed position is not recommended for those with heart issues or those susceptible to strokes.
7	Seating/Dining Mode: Simultaneously raises the backrest (30°) and legrest (40°) to maximise comfort and relaxation.
8	Exit Height: Lowers mattress deck to flat position and bed to a safe exit height. To set custom exit height, ensure mattress deck is flat and then raise/lower bed to desired height. Hold Exit Height 8 and Night Assist 12 buttons for 5 seconds to set the current height.

9	Zero Gravity: Simultaneously raises the backrest to 20° and legrest (also known as knee-break) to a 35° angle. This position helps to relax the circulatory system and muscles of the lower back, creating a sense of weightlessness.
10	Memory Preset: Not available on simplified handset. Nominate and adjust to your preferred position (x1 PRESET ONLY). To set up your memory function, first move the bed to desired positions. Then, hold 'M' 10 and Night Assist 12 button for 5 seconds.
11	Massage On / Off: First press turns ON massage at low speed, second press increases to medium and third press to high. Fourth press turns massage OFF. Massage will automatically turn off after 30 minutes.
12	Night Assist: Luminous underbed halo (lighting) for safe bed entry and exit throughout the night. Under bed light will turn off automatically after 12 hours.
13	Electronic System Reset: Resets electronic system in case of malfunction. Simultaneously press backrest up 3 and backrest down 3 buttons until mattress deck goes to flat position, bed lowers to minimum height and battery/LED indicator 1 flashes three times.
14	Electronic System Factory Reset: Resets bed to default settings (including exit and memory functions). Press Night Assist button 12 for 5 seconds until LED 1 starts flashing. While LED light flashes, simultaneously press Zero Gravity 9 and legrest up 4 buttons until mattress deck goes to flat position, bed lowers to minimum height and battery/LED indicator 1 flashes three times.

7. CASTOR OPERATION

TOTAL LOCKING CASTORS

Total locking castors are located at the foot end of the bed. The brakes need to be individually locked on both sides for improved safety and reduced bed movement.

1. To engage the brakes push down on the red pedal as shown below until bed is locked in place.
2. To disengage brakes pull up on the red pedal until the brake is unlocked.

PEDAL POSITIONS

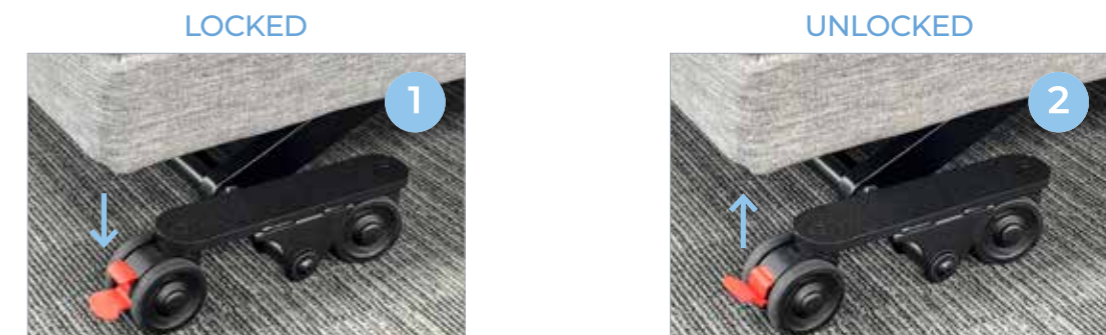

DIRECTIONAL LOCKING CASTORS

Directional locking castors are located at the head of the bed.

1. To engage the directional lock, ensure the latch is pushed down and secured within the wheel.
2. To disengage the directional lock, pull up on the latch until unlocked.



8. ASSEMBLY INSTRUCTIONS

GETTING STARTED

ComfiMotion Beds come securely packaged in a cardboard carton. Inside the carton you will find the retainers and hand control safely secured underneath the bed frame. The entire bed is also wrapped for further protection.

ComfiMotion Beds should arrive to you in pristine condition, ready for immediate assembly and installation.

TOOLS REQUIRED:

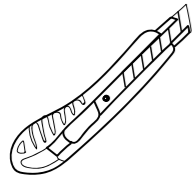

STANLEY KNIFE

TIPS

For easy installation we recommend using the ComfiMotion Bed Moving Trolley.



CARTON CONTENTS:

- 1 x ComfiMotion Bed
- 1 x Handset
- 1 x Headboard (Sold Separately)
- 8 x 75mm Locking Castors (mounted to bed frame)
- 4 x Side Mattress Retainers and Hardware
- 1 x Foot End Mattress Retainer



WARNING

ComfiMotion Beds are a large piece of equipment requiring special attention and careful handling at all times.



WARNING

When opening the carton, ensure it is done in a safe and careful manner. DO NOT USE a box cutter or sharp implement down the centre of the carton as this may damage the product.

8.1 BEDS

HOW TO UNPACK & INSTALL

Beds	Long Single BEB046740	King Single BEB046750
	Long Double BEB046760	Queen BEB046770

- 1 Remove bed from carton and position on flat surface or a Bed Moving Trolley for easy setup. Ensure the bed is placed TOP DOWN, so all components (hand control, retainers, castors & power cord) can be removed easily from the underside of bed.



DO NOT USE a box cutter, Stanley knife or sharp implement when opening the carton.

Doing so may cause irreversible damage to the product and void warranty.

- 2 Using a box cutter, unhook all components from the base of the bed (retainers, power cord, hand control and castors).

Retainers



Hand Control



Power Cord



8.2 HEADBOARDS

HOW TO ASSEMBLE OR MOUNT

ALLURE / CHESTERFIELD HEADBOARDS

Headboards	Allure (LS) BEA830120	Chesterfield (LS) BEA830100
	Allure (KS) BEA830130	Chesterfield (KS) BEA830110
	Allure (LD) BEB830132	Chesterfield (LD) BEB830112
	Allure (Q) BEB830134	Chesterfield (Q) BEB830114
	Allure (K) BEB830136	Chesterfield (K) BEB830116

- 3 Check handset is attached to the control box per section 6.1 Setting Up Your Handset(s).
For Long Double and Queen beds only: check dummy plug is installed in the port shown.



- 4 Cut safety securing straps that hold the bed in place when in carton.

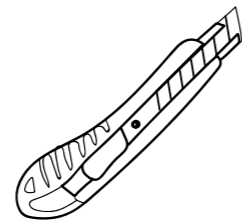

- 5 Turn bed FACE UP, secure 4 x mattress retainers (side) and 1 x mattress retainer (foot) in place by pushing into allocated slots. Finally, place the mattress onto the bed ensuring all mattress retainers hug the sides and footend.

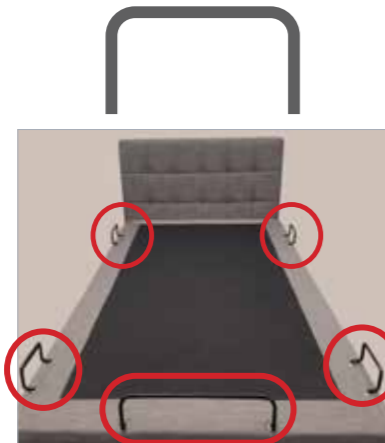

Side Mattress Retainer

Foot End Retainer



- 6 Conduct a Factory Reset to ensure control box and actuators are correctly synchronised before first use.

To conduct a factory reset:

Press Night Assist  button for 5 seconds until LED starts flashing. While LED light flashes, simultaneously press Zero Gravity  and legrest up  buttons until mattress deck goes to flat position, bed lowers to minimum height and battery/LED indicator flashes three times.

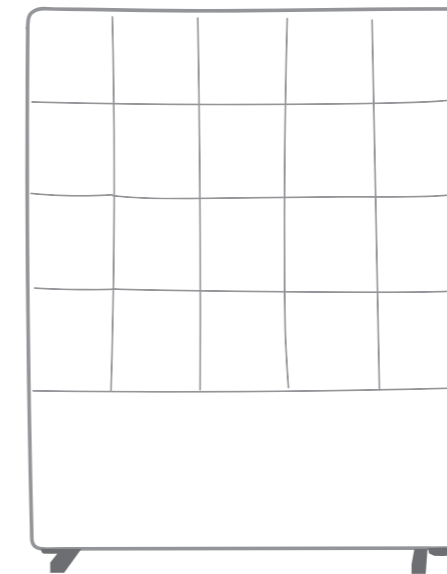

ALLURE HEADBOARD

OR

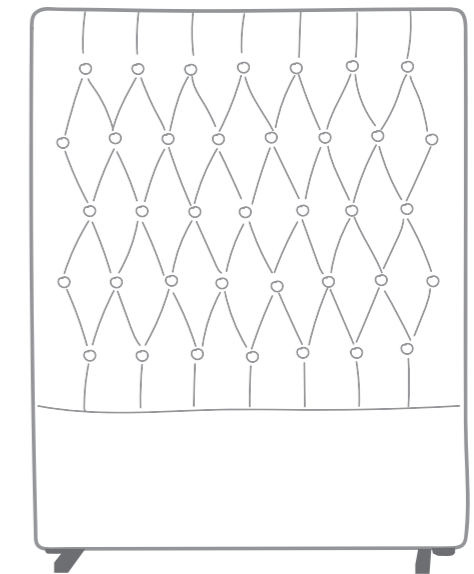

CHESTERFIELD HEADBOARD

FREESTANDING

(WITH STABILISERS)

For use on the:

-  ACTIV CARE BED
-  FIXED COMPANION BED

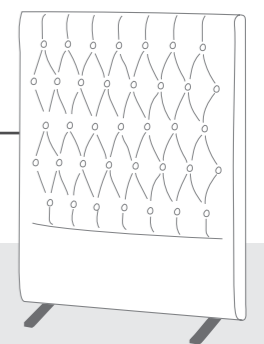

HOW TO ASSEMBLE – FREESTANDING WITH STABILISERS

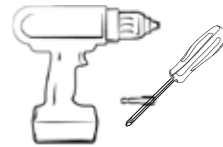

TOOLS REQUIRED:

- Impact driver or drill (5mm attachment)
- Phillips head screw driver (5mm)

For use on the:

- ✓ ACTIV CARE BED
- ✓ FIXED COMPANION BED



- 1 Flip headboard upside-down to show the black upholstery.
- 2 Using the leg stabiliser, align the holes to the white markings. **NOTE:** The short end of the stabiliser should face the back of the headboard (the side that will be positioned against the wall).

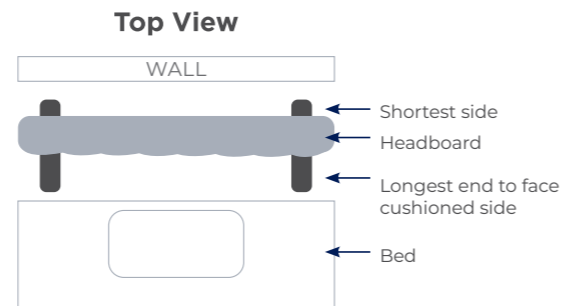
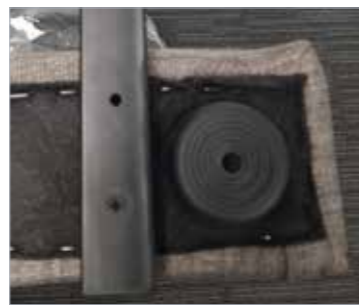

- 3 Secure the stabilisers in place using the screws provided.



- 4 Finally, flip the headboard back to its original position, enabling it to stand freely.



8.3 ACCESSORIES

HOW TO FIT TO BED

BED RAIL / BED STICK

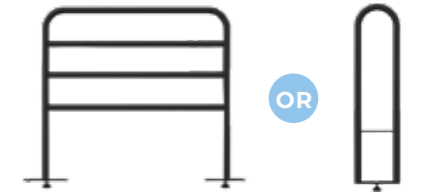

ACCESSORIES

Bed Rail BEA830212

Crook Handle BEA830211

For further installation and operating instructions, refer to the **User Manual**.



TOOLS REQUIRED:

- Allen Key (5mm)

KIT CONTENTS

Bed Rail

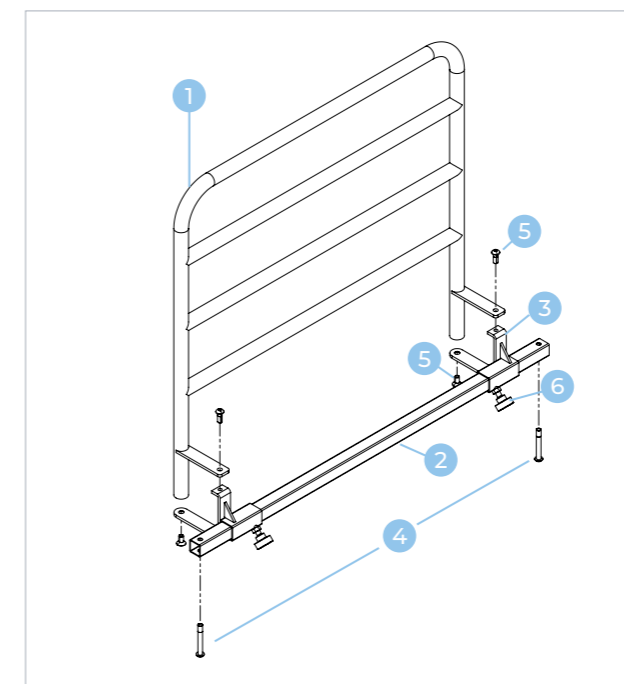

Crook Handle

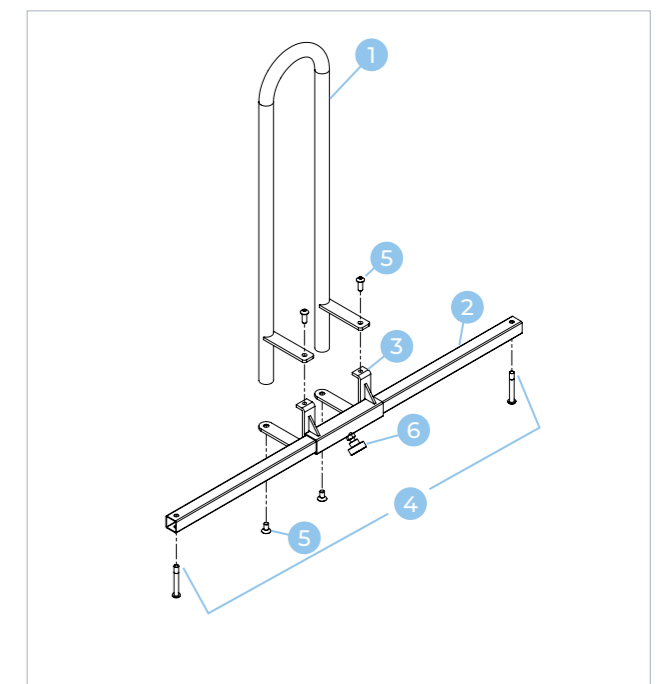

Item	Qty (Bed Rail)	Qty (Crook Handle)	Description
1	1	1	Rail
2	1	1	Mounting Tube
3	2	1	Mounting Bracket
4	2	2	M8 x 40 Bolt
5	4	4	M8 x 20 Bolt
6	2	1	Handwheel

1 Raise bed height, backrest and legrest to maximum height for ease of access.

To adjust:

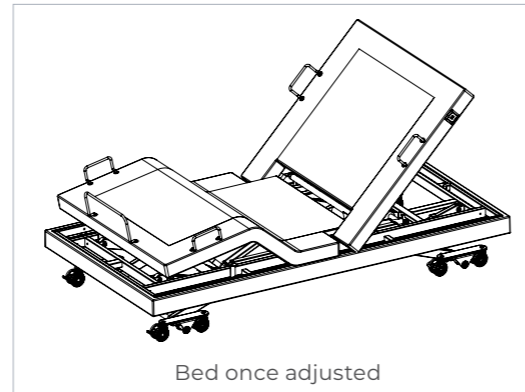

2 Slide the mounting bracket(s) 3 onto the mounting tube 2.
For bed rail: Ensure handwheel bolts are pointing towards each other as shown.

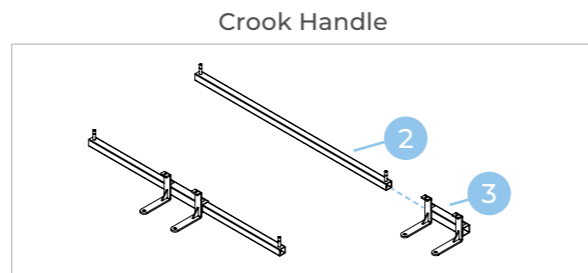
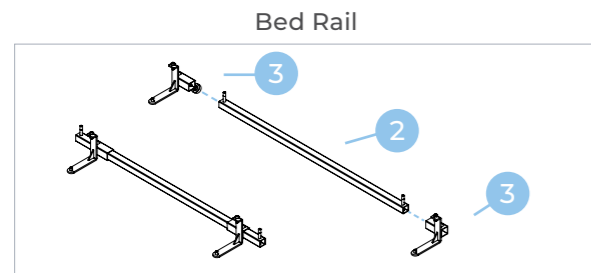

3 Assemble the mounting tube 2 onto the bed using the 40mm bolts 4.

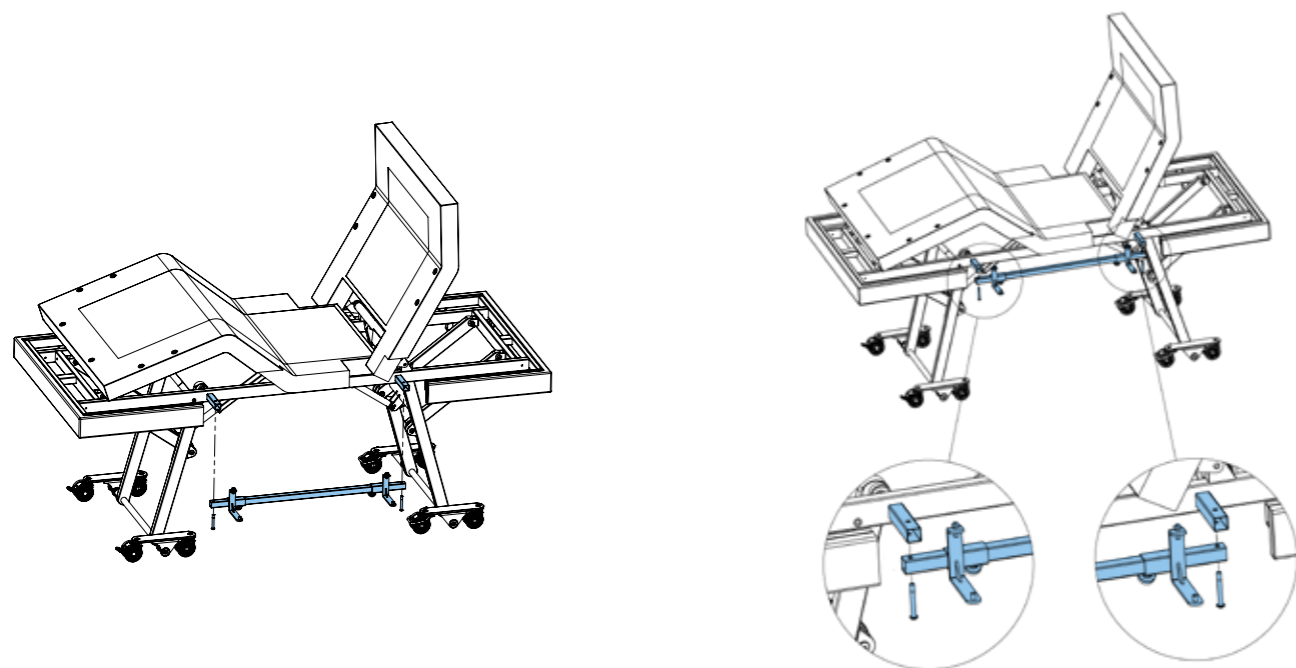

4 Mount the rail 1 to the mounting brackets 3 using the bolts 5.

NOTE: Images show assembly without the bed for clarity.

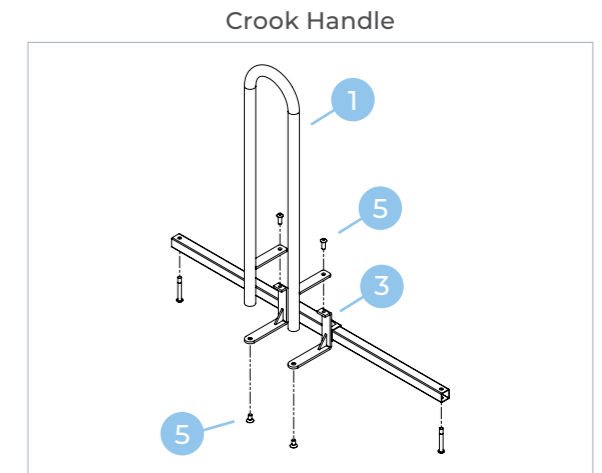
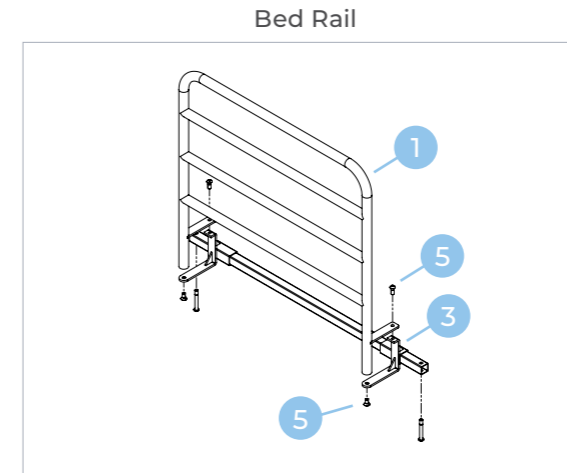

5 Loosen the hand wheel(s) 6 and gently slide rail 1 to desired position. Once in place, tighten the hand wheel(s) to lock in place.

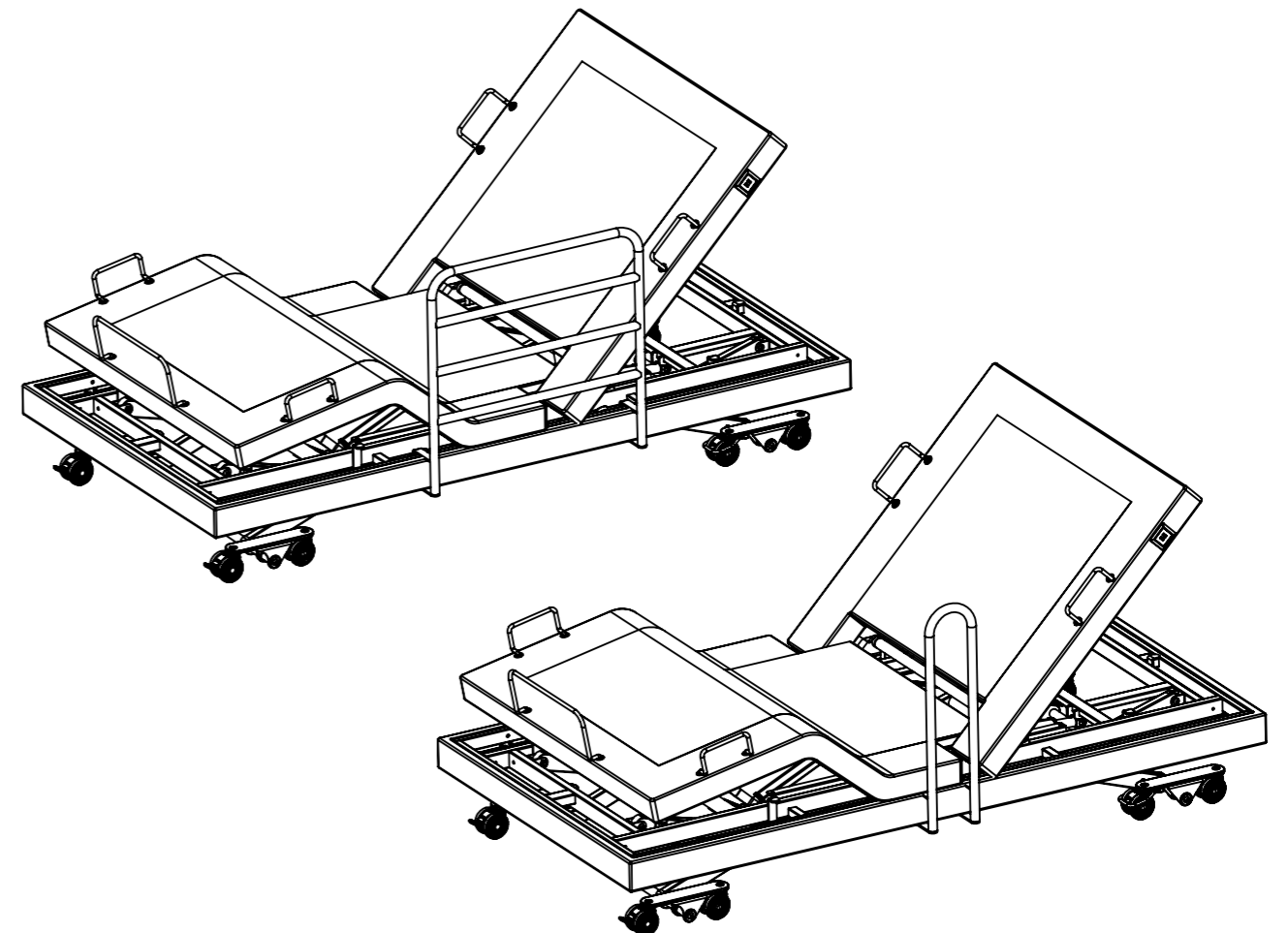

8.4 SPLIT KING UPGRADE KIT

Compatible with beds with serial numbers greater than CMAS-796260-00000 only.

Bed control boxes will need to be updated if serial numbers are not compatible.

The Split King upgrade kit allows two ComfiMotion ACTIV Care Long Single beds to be connected together and act as a Split King Bed. In this configuration the user can choose between two modes of operation:

- Full synchronization (all actuators including hi-lo, headrest, backrest and leg rest move together from one handset). This mode allows either one-piece king-size mattress or two single size mattress to be used and span both beds. Both users share the same bed positioning.

OR

- Partial synchronization (only hi-lo are synchronized from one handset while headrest, backrest and legrest remain independent). This mode allows each user to set their own desired bed positioning independent of their partner.



WARNING

The Split King bed is intended for use by two individuals each with a maximum patient weight of 200kg.



WARNING

The Split King bed is **NOT** intended for use by a single individual weighing more than 200kg even if no one else will be using the bed with them.



WARNING

The Split King bed is **NOT** intended to be used as a bariatric bed.

ACCESSORIES

Split King Upgrade Kit BEA830230

For further installation and operating instructions, refer to the **User Manual**.



TOOLS REQUIRED:

- Allen Key (5mm)

KIT CONTENTS



Item	Qty	Description
1	4	M8 x 20 Bolt
2	2	Connecting Bracket – Head
3	2	Connecting Bracket – Foot
4	1	Junction Box
5	1	Electrical Cord
6	2	M5 x 18 Bolt (not pictured)
7	4	Zip Ties (not pictured)

HOW TO INSTALL

Before installation, ensure both bed serial numbers are greater than CMAS-796260-00000. Otherwise, new control boxes need to be added to beds before installing the Split King Upgrade Kit.

- Remove all mattresses, bedding and/or packaging from both beds.
- Test both beds function and are free to move through all range of movements.
- Raise bed height, backrest and legrest to maximum height for ease of access. Do this for both beds.

To adjust:



HI-LO
Raise to Max

BACKREST
Raise to Max

LEGREST
Raise to Max



- Choose which of the two beds will be positioned on the RIGHT and which on the LEFT.

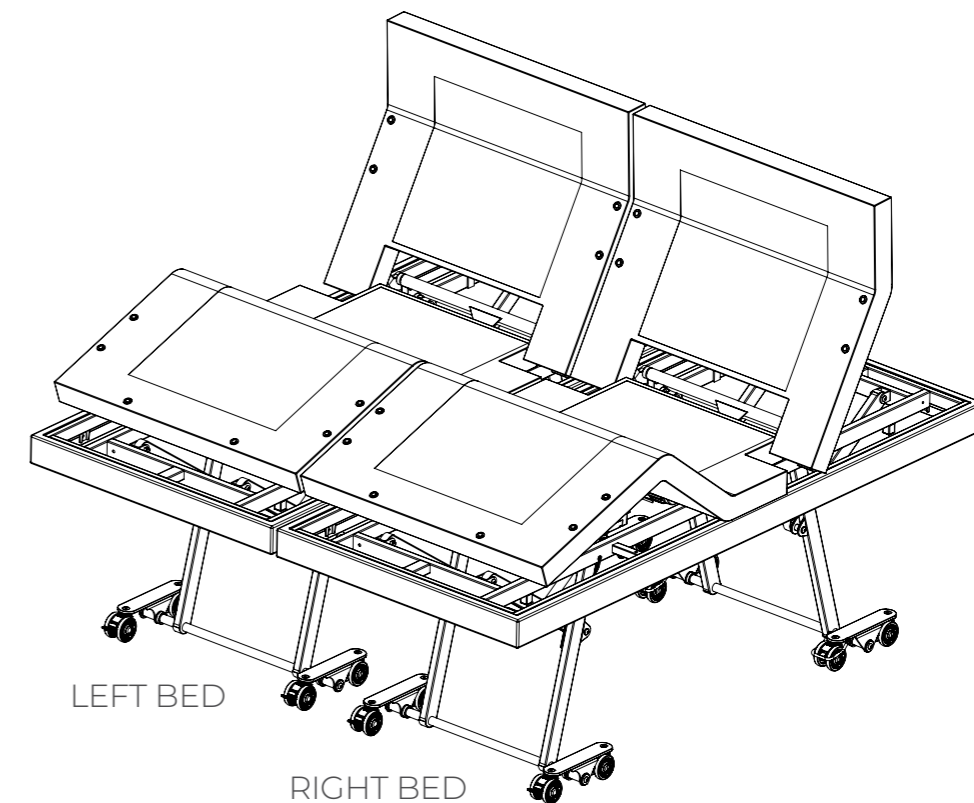

- 5 Assemble connecting brackets to each of the two beds, ensuring the brackets are mounted to the left side of the RIGHT bed and the right side of the LEFT bed.

NOTE: Ensure the hooks of each bracket are facing as shown for each bed.

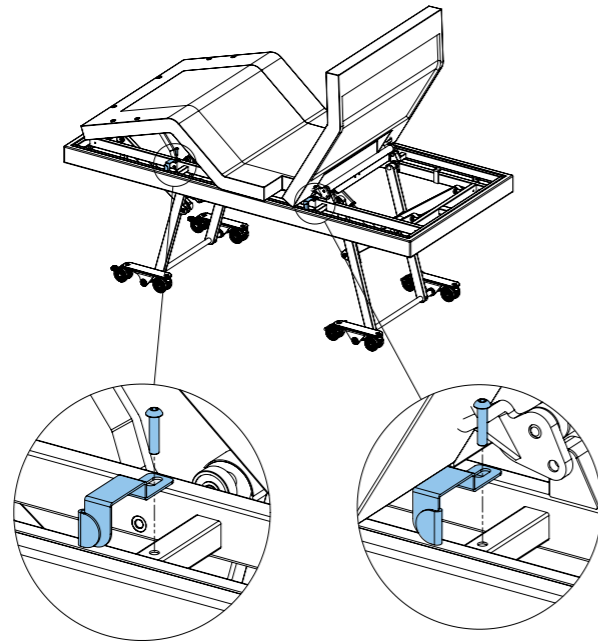

FOOT END BRACKET HEAD END BRACKET

- 6 To interlink the two beds together, first slightly lower the RIGHT bed and then position beds side by side. Ensure head ends of the bed are in-line. Once in position, slowly raise the RIGHT bed to match the LEFT bed height, ensuring the hooks from each bed slide into each other and interlink. Ensure both head and foot ends are interlinked.

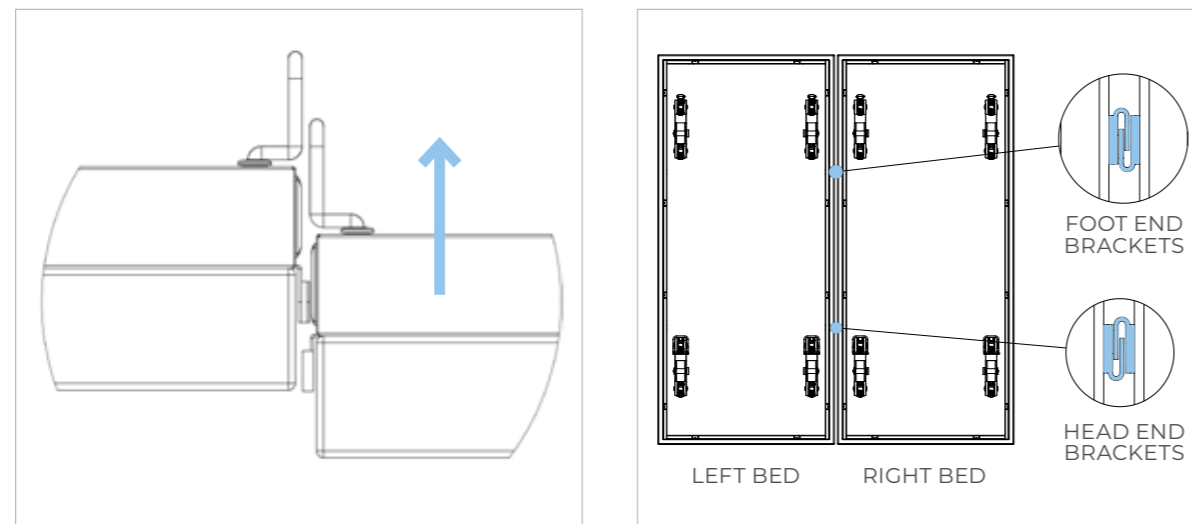

- 7 Gently push on beds to ensure they are interlinked and move side-to-side together.

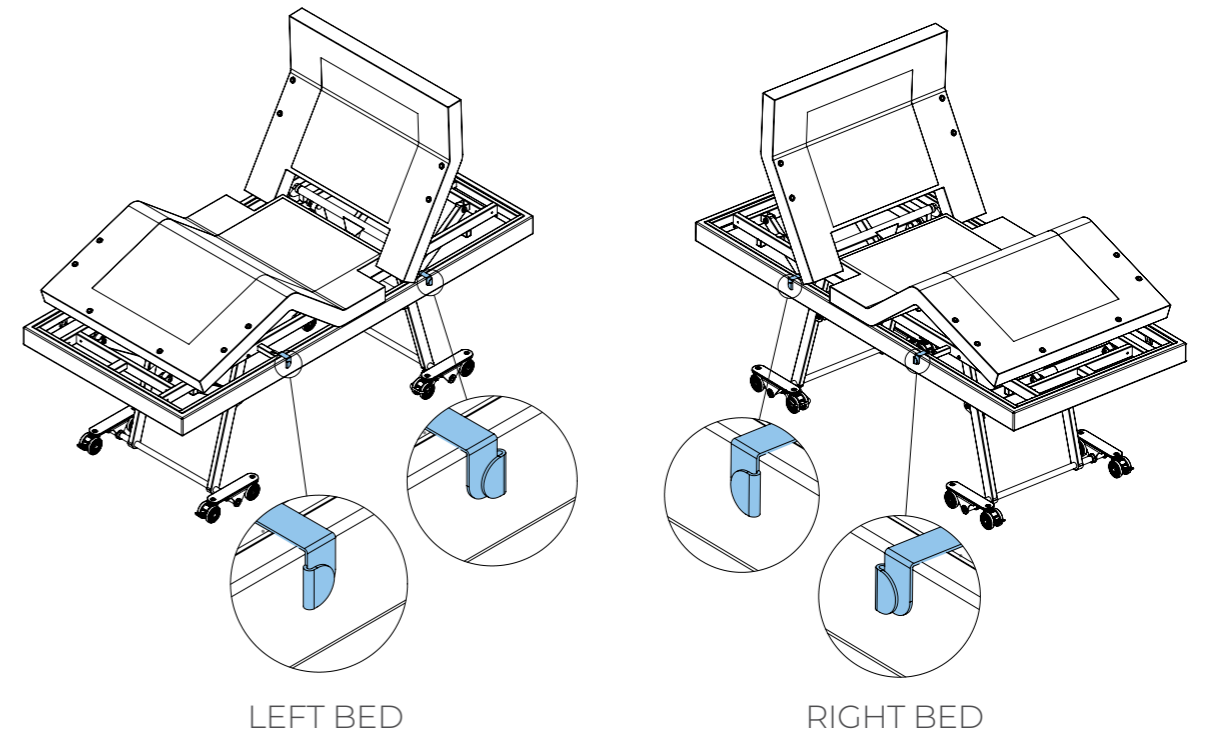

- 8 Attach the Junction Box 4 to the RIGHT bed in position shown using the M5 bolts 7.

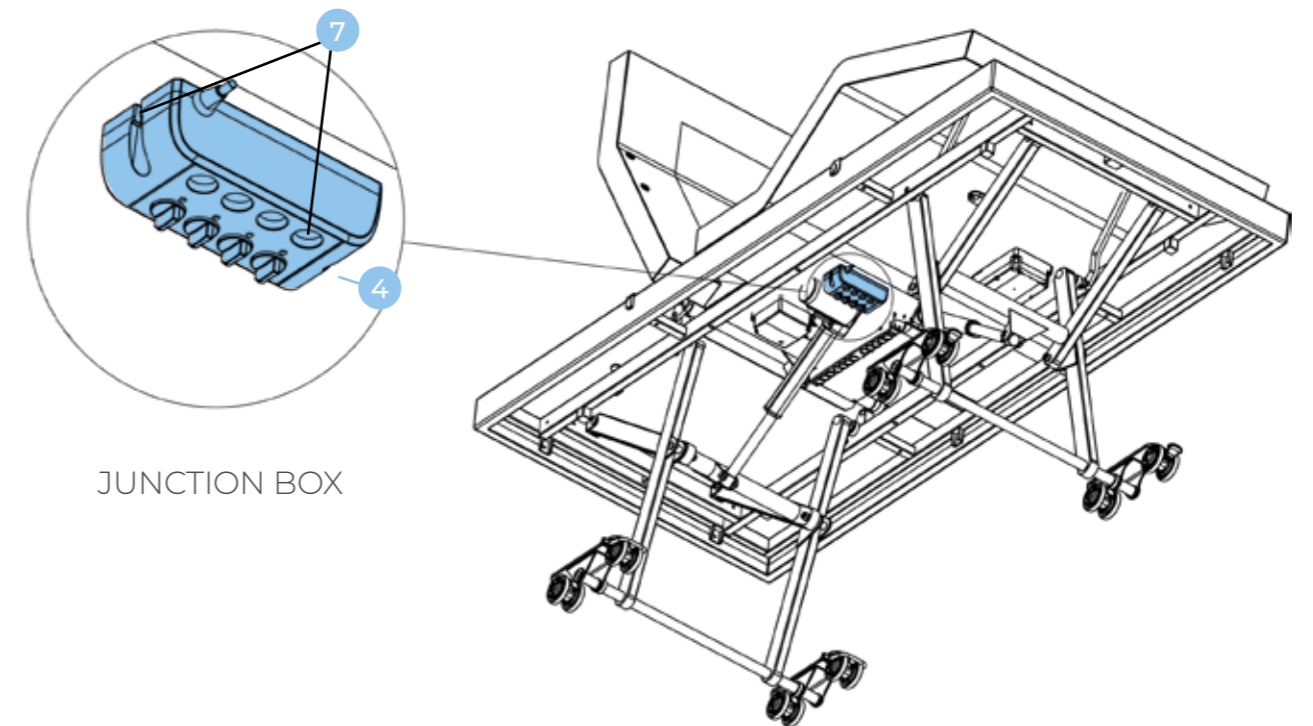

- 9 Connect the cord from the Junction Box 5 to port 4 of the control box of the RIGHT bed. Use zip ties to secure cable to bed frame if needed.

9. STORAGE & MOVEMENT

- 10 Connect the Electrical Cable 4 to port 4 of the control box of the LEFT bed.

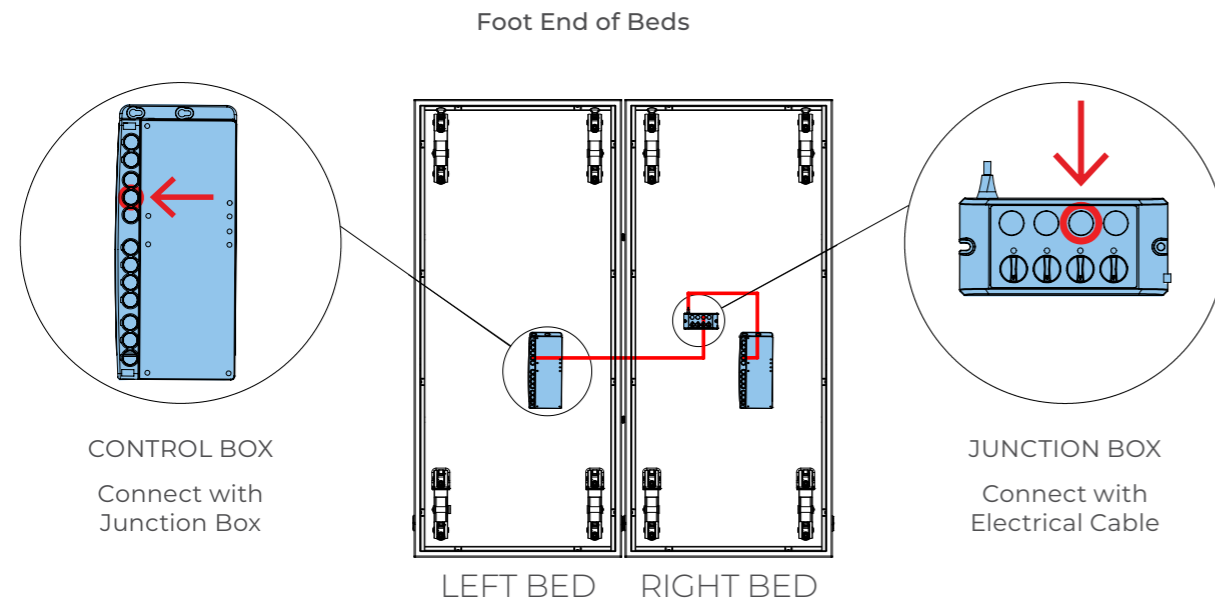

- 11 Connect the Control Box from LEFT bed to the Junction Box on RIGHT bed.
WAIT 30 seconds without pressing any buttons on hand control.
- 12 Test beds are connected by pressing hi-lo button from one handset. Both beds should move together.
- 13 Secure Electrical Cable 6 to LEFT bed using zip-ties if needed.
- 14 To complete set up, run a Factory Reset (See Section 6 – Handset Operation) from one of the handsets during which time the beds will lower to minimum height and control boxes will synchronise the two systems.

After factory reset the handset backlight will turn off allowing the user to select which split king mode is preferred:

- Full synchronization (all actuators including hi-lo, headrest, backrest and leg rest move together) – press (Massage button)
- Partial synchronization (only hi-lo are synchronized while headrest, backrest and legrest remain independent) – press (Underbed light)

If no selection is made within 10 seconds, then the system will default to full synchronization mode.

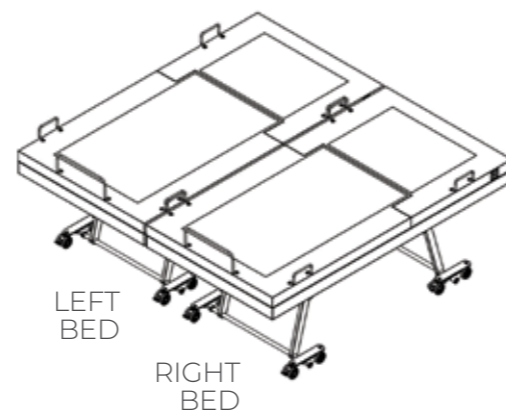

Do not press handset buttons until the handset backlight turns back on which will take approximately 10 seconds after selection is made.

The beds should now raise and lower simultaneously.



WARNING

DISCONNECT the bed power cord before moving the bed.

DO NOT remove the power cord from the source by pulling on the cord.

DO NOT pull on the power cord, or handset cord to manoeuvre the bed.

ALWAYS APPLY THE BRAKES when the bed is in a stationary position.

HANDLE WITH CARE

- ComfiMotion Beds should be stored in a clean, dry, well ventilated area.
- Do not drop and avoid shock or violent impact when transporting.
- Aidacare offers many bed moving trolley options, please contact us for further information on **1300 133 120** or visit our website at aidacare.com.au.

COMFIMOTION COMPACT TRANSPORT TROLLEY

Bed frame mechanisms arrive in the box secured with fasteners to minimise loading difficulty and centralise the bed centre of gravity for loading.

KEY FEATURES

- **Tight Turning Radius:** Short wheel base with large low resistance castors make manoeuvring through tight spaces manageable.
- **Reduce Stock Damage:** Padded trolley surfaces protect the fragile upholstery of the bed surround, reducing damage during freight and handling.
- **WHS Outcomes:** Safety strap and lockable castors make loading and unloading the trolley a simple process.

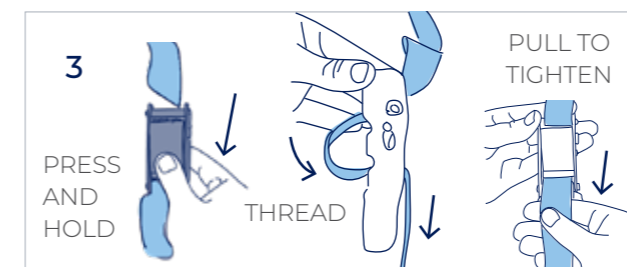
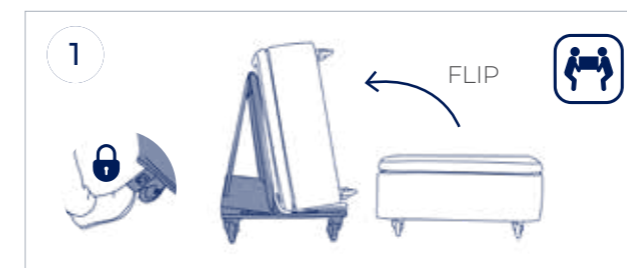

10. CLEANING



BEFORE CLEANING always disconnect the bed from the mains power source.

NOTE: It is strongly recommended that protective clothing be used when cleaning.

NOTE: The following procedure also applies to bed accessories, but does not include mattresses.

- Wipe the beds surfaces with a soft cloth moistened with hot water and mild detergent.
- Rinse with clean water and dry with a clean cloth.
- Ensure bed upholstery is only lightly wiped, it is important not to leave this wet after cleaning.
- Allow the cleaned parts to dry before replacing the mattress.



DO NOT clean with bleach!

11. SERVICE & MAINTENANCE

To prolong the working life of the bed and for trouble free operation it is recommended that routine inspections should be performed by a person who is suitably qualified and well acquainted with the design, use and care of ComfiMotion beds.

If inspection reveals that the safety of the bed is jeopardised in any way, it should be IMMEDIATELY WITHDRAWN FROM SERVICE, tagged as such and the owner notified, until repair or replacement has occurred.

INSPECTION:

- A visual and functional inspection should be performed monthly
- Visually inspect electrical components: can you see damage to the hand control or power cord?
- Visually inspect mechanical components: can you see damage, chips or deformation to the frame, headboard or accessories?
- Is the hand control functioning as it should?
- Are the castors, brakes and accessories functioning as they should?

PREVENTATIVE MAINTENANCE:

The following preventative maintenance procedures should be carried out every 12 months or as otherwise specified:

NOTE: Other than general maintenance activities all other service or repair work must be performed by qualified and trained persons or agents approved by Aidacare.

- Overall functional check that all hand control functions are operating the bed as expected.
- Overall inspection for visible signs of wear, tear or damage to the integrity of electronics and Cables.
- Actuators and all moving components should not make unusual noises.

NOTE: If you are unsure if your ComfiMotion bed is working correctly, Contact Aidacare or your local authorised Aspire Dealer.

12. TROUBLESHOOTING

EFFECT	POSSIBLE CAUSE	VERIFICATION	CORRECTIVE ACTION
Bed does not stay in place	Locking castors not preventing bed movement. Brake System is malfunctioning.	Not all locking castors have been engaged. Brake pedal is in lowest position, but bed does not stay in place.	Engage 2 x locking castors on the foot end of the bed (both sides) . If this does not work, contact your sales representative or a qualified Aidacare service technician.
Bed does not move as expected when pressing handset buttons	Electronics plugged into control box incorrectly. System was not reset after power failure or electronic components plugged/unplugged to/ from control box.	Bed acts differently to what is defined in section 6.2 Handset Operation.	Conduct Electronics System Reset procedure (see steps 13 and 14 in section 6.2 Handset Operation). Contact your sales representative or a qualified Aidacare service technician. <i>Check installation is correct per Section 6.</i>
Massage motor is noisy	Massage motor faulty. Loose R clips on actuator mounts. Loose components on bed. Actuator mounts missing springs.	Unplug massage motors one at a time to see if one is more noisy. Check actuator mounts for loose R clips. Check bed frame for any loose components that can make noise during massage vibration.	Replace massage motor. Replace R clip on actuator mounts. Add springs to actuator mounts. Fix/replace any loose components.

13. WARRANTY AND SERVICE

13.1 BEDS AND ACCESSORIES

Congratulations on the recent purchase of your Aspire ComfiMotion bed, mattress and/or accessories. ComfiMotion beds and accessories carry a comprehensive warranty as detailed below (see 15.2 Mattresses for mattress warranty information). Please keep proof of purchase for proof of warranty commencement.

BEDS

ACTIV CARE	10 Years warranty	Frame
	2 Years warranty	Electronics
	1 Year warranty	Handset, cables and fabric
FIXED COMPANION	10 Years warranty	Frame
	1 Year warranty	Fabric

ACCESSORIES

BED RAIL BEA830212 CROOK HANDLE BEA830211	5 Years warranty	
HEADBOARDS	1 Year warranty	Chesterfield + Allure

SPLIT KING UPGRADE KIT

BRACKETS	1 YEAR WARRANTY
ELECTRONICS	2 YEARS WARRANTY

PILLOWS

BREEZE BEP050100	1 Year warranty
PLUSH BEP050110	1 Year warranty

MATTRESSES*

MEMORY FOAM	10 Years limited warranty
POCKET SPRING	5 Years limited warranty

*More details on next page.

CONSUMER WARRANTY AGAINST DEFECTS:

Aidacare is bound by Australian Consumer Law in respect to Warranty Against Defects. A copy of the Aidacare Warranty Against Defects statement is available on the Aidacare homepage at aidacare.com.au. All warranty matters should be directed to Aidacare Customer Service on 1300 133 120.

Aidacare does not warrant against excessive or incorrect use, modification or any situation that could not be deemed as fair wear and tear. This is a back to base warranty and does not cover freight costs pertaining to the return of any items under warranty. Aidacare acknowledges and conforms to all ACCC guidelines around consumer rights. For further information contact Aidacare on 1300 133 120 or email product@aidacare.com.au

Aidacare will not warrant the safety and or correct functioning of products where any original components have been changed or modified by non-Aidacare approved and trained service & maintenance staff or external providers. Furthermore, safety is not guaranteed where components have been replaced with non-original Aidacare approved parts. If any faults are detected upon receipt of this product please phone Aidacare. Any faults that are detected during normal use should be reported to Aidacare immediately to determine if warranty conditions apply and if so, the necessary repair or replacement work to be completed.

Spare parts list is available upon request.

For servicing, preventative maintenance and any other questions regarding this or any other Aidacare product please contact:

Aidacare Pty Ltd
 Building 3A, 1 Moorebank Avenue
 Moorebank NSW, Australia 2170
 T: 1300 133 120 | W: aidacare.com.au | E: product@aidacare.com.au

13.2 MATTRESSES

COMFIMOTION MATTRESSES

MEMORY FOAM	10 Years limited warranty
POCKET SPRING	5 Years limited warranty

The below information outlines the terms and conditions of your limited mattress warranty, it should be noted that your specific legal rights may vary from state to state.

I. PRODUCTS COVERED BY THIS LIMITED MATTRESS WARRANTY

This limited mattress warranty extends to mattresses manufactured by Aidacare Pty Ltd. ("Aidacare") under the Aspire brand, purchased directly from Aidacare or an Aspire ComfiMotion approved second party distributor located in Australia.

Mattresses are designed to work on a firm, solid and well-ventilated bed base that is structurally capable of supporting the weight of the mattress and user(s). This mattress Warranty does not cover your Product if you use it in a manner incompatible with that intended design.

II. WHO IS COVERED BY THIS MATTRESS WARRANTY?

This limited mattress warranty extends to the original purchaser of an Aspire ComfiMotion Memory Foam and/or Pocket Spring mattress who is located in Australia and complies with the products intended use. All Aspire ComfiMotion warranties, including any implied warranties, are valid only for the period of time the mattress is owned by the original purchaser of the mattress. The "original purchaser," for the purposes of this mattress warranty, is the first purchaser of the mattress from Aidacare or an Aspire ComfiMotion approved second party distributor. Please retain a copy of your receipt as proof of purchase. All Aspire ComfiMotion limited warranties are not transferable.

III. ASPIRE COMFIMOTION LIMITED MATTRESS WARRANTY AND RESPONSIBILITIES

Aidacare warrants the Aspire ComfiMotion mattresses in its original packaging sold to you against the defects in material and workmanship set forth below ("defects") for a period of:

- **10 Years** for Aspire ComfiMotion **Memory Foam** Mattress **or,**
- **5 Years** for Aspire ComfiMotion **Pocket Spring** Mattress

from the time your mattress is purchased by you, when the mattress is used normally for its intended purposes and on a bed base that is structurally capable of supporting the weight of the mattress and user(s).

IV. WHAT IS COVERED?

Defects covered by this limited mattress warranty **include:**

MEMORY FOAM	POCKET SPRING
<p>✓ Deterioration causing the mattress to have a visible indentation greater than 25 millimetres that is not associated with an indentation or sag which results from use of an improper or unsupportive foundation or adjustable bed base. Normal wear requires that a mattress be continuously supported by a matching foundation or adjustable bed base with a proper bed frame sufficient to support the collective weight of the mattress and foundation.</p>	<p>✓ Deterioration causing the mattress to have a visible indentation greater than 32 millimetres that is not associated with an indentation or sag which results from use of an improper or unsupportive foundation or adjustable bed base. Normal wear requires that a mattress be continuously supported by a matching foundation or adjustable bed base with a proper bed frame sufficient to support the collective weight of the mattress and foundation.</p>
<p>✓ Any physical flaw in the mattress that causes the foam material to split or crack, despite normal usage and proper handling.</p>	<p>✓ Coils or wires that protrude or have torn the fabric.</p>
<p>✓ Any manufacturing defect in the assembly of the Aspire ComfiMotion Memory Foam Classic or the Multistretch Pressure Care mattress cover that may affect the products performance.</p>	<p>✓ Coils or wires that are loose or broken.</p>

The Aspire ComfiMotion Memory Foam Mattress is strictly intended for domestic use only. This product is NOT intended for hoteling, commercial, hospital, specialised or commercial care usage, prevention or treatment of pressure injuries. It is strongly recommended to consult an Occupational Therapist and/or health professional for prescribed and specialised care solutions.

V. EXCLUSIONS

The Aspire ComfiMotion limited mattress warranty **does not** include:

A normal increase in softness of the foam pressure-relieving material or pocket spring coils which does not affect the pressure-relieving and/or supportive qualities of the mattress.

Comfort preference.

The defect is caused as a result of the product being bent, squeezed, exposed to cold temperatures or damp conditions for a period of time causing the material to tear or permanently deform.

The product has been wet, soaked or exposed to harsh climate conditions such as flooding or humidity, against Aidacare's recommendations.

The mattress or mattress cover is found to be very stained, soiled and/or otherwise unhygienic.

The product has been altered or repaired without the Aidacare's prior permission.

The use of mattress on base slats more than 75 millimetres.

Physical abuse or damage to the structure and/or cover material, including but not limited to, burns, cuts, tears, heat or liquid damage (including bleach or products containing such), or stains; provided, that the defect is caused by such abuse or damage.

Minor manufacturing anomalies that do not impact the performance of the mattress (including mis-stitching on quilting and/or the cover).

Any mattress (whether manufactured by Aidacare or not) sold by resellers who are not authorised retailers.

Mattresses sold "as-is", "preconditioned", "reconditioned", "used", "comfort return", "returned", "previously owned", or any other similar wording indicating that the mattress is not "new" or of "first quality", or has previously been purchased or used by another consumer.

In the event of a defect, Aidacare's sole and exclusive liability and your sole remedy under this limited mattress warranty will be, at Aidacare's discretion, to provide a replacement mattress or mattress cover, subject to your fulfilment of "Your Responsibilities" below. Aidacare will endeavour to replace the product from the same line. However, should the mattress or mattress cover be discontinued or unavailable, a substitute product will be issued as the replacement. The replacement mattress or mattress cover may vary in colour, style or design from the original product purchased.

VI. YOUR RESPONSIBILITIES

In the event of a defect and in order to get the benefit of this limited mattress warranty, you must return your mattresses to the original place of purchase and provide Aidacare or an Aspire ComfiMotion approved second party distributor with proof of the original date of purchase. Should shipping costs be required to return your mattress, you will not be responsible for those costs.

Evidence of a defect and any claims must be sent to place of purchase (Aidacare or an Aspire ComfiMotion approved second party distributor) before the limited mattress warranty expires.

CONSUMER WARRANTY AGAINST DEFECTS:

Aspire does not warrant against excessive or incorrect use, modification or any situation that could not be deemed as fair wear and tear. This is a back to base warranty and does not cover freight costs pertaining to the return of any items under warranty. Aspire acknowledges and conforms to all ACCC guidelines around consumer rights.

Aspire will not warrant the safety and or correct functioning of products where any original components have been changed or modified by non-Aspire approved and trained service and maintenance staff or external providers. Furthermore, safety is not guaranteed where components have been replaced with non-original Aspire approved parts. If any faults are detected upon receipt of this product please contact Aspire. Any faults that are detected during normal use should be reported to Aspire immediately to determine if warranty conditions apply and if so, the necessary repair or replacement work to be completed.

AIDACARE PTY LTD

Building 3A, 1 Moorebank Avenue,
Moorebank NSW Australia 2170

1300 133 120 | comfimotion.com.au

ASUM80.34 081222

