



TILT IN SPACE WHEELCHAIR RANGE

USER MANUAL



REHAB RS



REHAB RX



REHAB RX
JNR

TABLE OF CONTENTS

1. Intended Use _____	5
2. Product Description _____	5
3. Warnings _____	6
4. Product Specifications _____	7
5. List of Components _____	8
6. Assembly _____	10
7. Preliminary Checks _____	12
8. General Operation _____	12
9. Adjustments _____	17
10. Accessories _____	21
11. Troubleshooting _____	23
12. Care & Maintenance _____	24
13. Warranty _____	25
14. Compliance _____	26
15. Service Maintenance & Customisation _____	26
16. Service Log Book _____	27

Thank you for choosing this Aspire Wheelchair.

This product has been designed to offer the maximum in comfort, safety and adjustability. Aspire Manual Wheelchairs are suitable for indoor and outdoor use and are available in a range of sizes.

It is important that you read this user manual carefully before using your new wheelchair.

SYMBOLS USED IN THIS MANUAL

The symbols below are used throughout this user manual and on the product to identify warnings and important information. It is very important for you to read them and understand them completely.



WARNING! Indicates a potentially hazardous condition/situation. Failure to follow designated procedures can cause either personal injury, component damage or malfunction. On the product, this icon is represented as a black symbol on a white triangle with a black border.



ALWAYS! These actions should be performed as specified. Failure to perform mandatory actions can cause personal injury and/or equipment damage. On the product, this icon is represented as a white infinity symbol on a black dot with a white border.



DO NOT! These actions are prohibited. These actions should not be performed at any time or in any circumstances. Performing a prohibited action can cause personal injury and/or equipment damage. On the product, this icon is represented as a white symbol with a black circle and black slash.

1. INTENDED USE

Aspire Rehab Tilt In Space Wheelchairs are designed to provide assistance and increased independence for individuals who have limited mobility, are immobile or require sitting support and positioning.

The Aspire Rehab range of Tilt in Space wheelchairs can be propelled by the occupant via the rear wheel hand push rims, or by an attendant using the rear mounted push handles behind the backrest.

These wheelchairs have been designed for use indoors and outdoors, where the surface terrain is dry, hard and level.

The highly configurable seating system facilitates the scope to grow or shrink with changing occupant needs and the chairs have passed international standards testing for safety, stability, durability and safe transportation of occupants in motor vehicles.



WARNING! This wheelchair is intended to bear the weight of an occupant through its wheels during propulsion and when stationary. It is NOT designed to be carried with an occupant in the seat and doing so may cause serious injury or death.

2. PRODUCT DESCRIPTION

Aspire Rehab Tilt in Space Wheelchairs are designed for durability and offer a robust steel frame construction.

These wheelchairs offer exceptional manoevrability and stability, and all components are European designed and manufactured in top tier production facilities.

Comfort and adjustability are the primary focus of these wheelchairs, offering a holistic mobile support surface that boosts quality of life through independence and increased mobility.

A wide range of accessories have been designed to compliment the Aspire Rehab Wheelchair range, broadening its application across Acute, Rehab, Long-Term Care and Community care environments.

3. WARNINGS

MAXIMUM WEIGHT CAPACITY - 180KG

The maximum weight capacity for safe transportation of an occupant in a motor vehicle is 135kg.

The foot plates are not designed to be a weight bearing surface. Never stand on the footplates as the wheelchair may tip over.

Be careful to protect your fingers from becoming trapped in any tight spaces when assembling the wheelchair.



ALWAYS take care to keep fingers and hands free from rear wheel spokes and maintain focus on occupant limb positioning when tilting and reclining the wheelchair.



DO NOT use the wheelchair on escalators, even if accompanied by an attendant



DO NOT exceed maximum occupant weight. This weight limit includes any accessories, shopping or other personal items that may be carried on the chair.



DO NOT stand on the foot plates as the wheelchair may tip forwards. The foot plates are not designed to be a weight bearing surface.



WARNING! Pay attention to your fingers when assembling/disassembling the wheelchair and when self-propelling the chair with hands in close proximity to wheel spokes.



ALWAYS use push rims to bring the wheelchair to a stop. Do not use the brakes to stop a moving wheelchair.



DO NOT use the wheelchair on escalators, even if accompanied by an attendant.

4. PRODUCT SPECIFICATIONS

Aspire Rehab RS Tilt in Space Manual Wheelchair

CODE	OVERALL WIDTH	SEAT WIDTH	SEAT DEPTH	SEAT HEIGHT	BACKREST HEIGHT	ARMREST HEIGHT	CHAIR WEIGHT	S.W.L
REHAB RS								
MWS449600	690 mm	410 - 460 mm (16" - 18")	440 - 530 mm	Front = 410 - 440 mm Rear = 400 - 475 mm	460 - 710 mm	310 - 460 mm	40.7 kg	180 kg
MWS449610	740 mm	460 - 510 mm (18" - 20")	440 - 530 mm	Front = 410 - 440 mm Rear = 400 - 475 mm	460 - 710 mm	310 - 460 mm	42.5 kg	180 kg
MWS449620	790 mm	510 - 560 mm (20" - 22")	470 - 560 mm	Front = 410 - 440 mm Rear = 400 - 475 mm	460 - 710 mm	310 - 460 mm	46.7 kg	180 kg

Aspire Rehab RX Tilt in Space Manual Wheelchair

CODE	OVERALL WIDTH	SEAT WIDTH	SEAT DEPTH	SEAT HEIGHT	BACKREST HEIGHT	ARMREST HEIGHT	CHAIR WEIGHT	S.W.L
REHAB RX								
MWS449710	690 mm	410 - 460 mm (16" - 18")	440 - 530 mm	Front = 410 - 440 mm Rear = 400 - 475 mm	460 - 710 mm	310 - 460 mm	41 kg	180 kg
MWS449720	740 mm	460 - 510 mm (18" - 20")	440 - 530 mm	Front = 410 - 440 mm Rear = 400 - 475 mm	460 - 710 mm	310 - 460 mm	43 kg	180 kg
MWS449740	790 mm	510 - 560 mm (20" - 22")	470 - 560 mm	Front = 410 - 440 mm Rear = 400 - 475 mm	460 - 710 mm	310 - 460 mm	47.2 kg	180 kg

Aspire Rehab RX JNR Tilt in Space Manual Wheelchair

CODE	OVERALL WIDTH	SEAT WIDTH	SEAT DEPTH	SEAT HEIGHT	BACKREST HEIGHT	ARMREST HEIGHT	CHAIR WEIGHT	S.W.L
REHAB RX JNR								
MWS449630	600 mm	320 - 370 mm (13" - 15")	440 - 490 mm	Front = 410 - 440 mm Rear = 400 - 475 mm	460 - 710 mm	310 - 460 mm	39.5 kg	180 kg

5. LIST OF COMPONENTS

Aspire Rehab RS Tilt in Space Manual Wheelchair



Number	Description
1	Rear Wheels
2	Quick Release Axles
3	Armrests
4	Elevating Legrests
5	Height Adjustable Castor Fork
6	Front Castor Wheel
7	Foot Plate with Heel Loop
8	Attendant Hand Grips
9	Hand Brakes
10	Headrest
11	Tilt in Space Hand Controls

Aspire Rehab RX Tilt in Space Manual Wheelchair



Number	Description
1	Rear Wheels
2	Quick Release Axles
3	Armrests
4	Elevating Legrests
5	Height Adjustable Castor Fork
6	Front Castor Wheel
7	Foot Plate with Heel Loop
8	Attendant Hand Grips
9	Hand Brakes
10	Headrest
11	Tilt in Space Hand Controls

Aspire Rehab RX JNR Tilt in Space Manual Wheelchair



Number	Description
1	Rear Wheels
2	Quick Release Axles
3	Armrests
4	Elevating Legrests
5	Height Adjustable Castor Fork
6	Front Castor Wheel
7	Foot Plate with Heel Loop
8	Attendant Hand Grips
9	Hand Brakes
10	Headrest
11	Tilt in Space Hand Controls

6. ASSEMBLY

How to assemble Aspire Rehab Tilt In Space Wheelchairs

Box Contains:

1. Wheelchair frame fitted with 24 inch (Rehab RS & RX) & 16 inch (Rehab RX JNR) rear wheels
2. Elevating legrests (pair)
3. Back cushion
4. Seat cushion
5. Headrest (mounted to chair)
6. Tool adjustment kit
7. User manual



When opening the carton, ensure it is done in a safe and careful manner. DO NOT USE a box cutter or sharp implement as this may damage the product. For OH&S purposes, lay the carton on its side with the top of the carton open and slide the plastic bag out containing the wheelchair and the small carton box containing the swing away legrests.

**Rehab RS model shown in instructional images*

1. Stand the wheelchair in an upright position on the ground



2. The backrest will be lying flat on the seating surface. Pull back to manoeuvre into place



3. Lock backrest in place by aligning gas strut with mounting bracket, fasten with locking pin and clip



4. Insert the elevating legrests into the top of the frame receivers at a 45° angle to the chair and swing them in towards the centre of the chair until the release button engages with a 'click' sound



5. Place seat cushion on seat base, aligning with velcro strips to ensure correct positioning

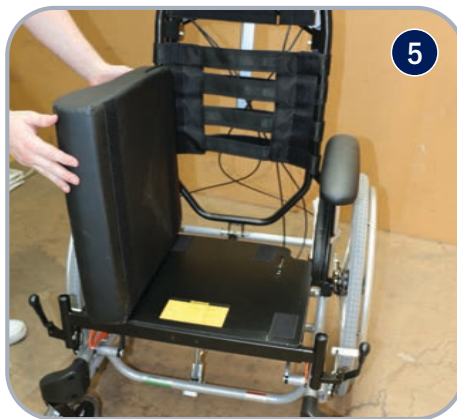

6. Place back cushion on backrest frame, aligning with velcro strips to ensure correct positioning



7. Flip up headrest and lock in place with fastening hand pins



7. PRELIMINARY CHECKS

After assembling the wheelchair, these checks should be completed prior to initial use:

1. Arm rests should be securely in place with the push pin button visible below the mounting bracket
2. Rear quick release wheel axles should be securely locked in place
3. Brakes should stop rear wheels from rotating when locked and allow free wheel rotation when disengaged
4. Tilt and Recline functions should operate smoothly throughout range
5. Accessories should be fastened correctly (where fitted)

8. GENERAL OPERATION

General Operation

It is very important that this wheelchair is used under guidance from all warnings or hazards listed in this occupant manual. Key safety measures should be taken by both occupants and attendants when operating this wheelchair:

- Avoid quick direction changes
- Ensure your wheelchair is used on surfaces intended for its use
- Control the speed of the wheelchair using the hand rims on the rear wheels
- Ensure an attendant is available to assist where necessary

Lifting the Wheelchair

Lift the wheelchair using the push handles and the front upper corners of the wheelchair frame, where the legrests are attached.

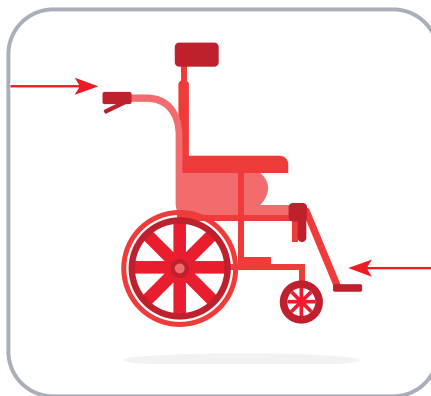

 **ALWAYS!** ensure a minimum of two people lift the wheelchair to prevent manual handling issues.

 **WARNING! DO NOT** lift the wheelchair by holding it by the legrests or the armrests! Detach the legrests prior to lifting the chair.

 **DO NOT** lift the wheelchair with an occupant in it under any circumstances. This is expressly outside the Intended Use of the wheelchair.

Transporting the Wheelchair (occupied)

Aspire Rehab RS, RX & RX JNR wheelchairs are compliant to AS/NZS 3696.19 (Wheelchairs wheeled mobility devices for use as seats in motor vehicles) and are approved to be used in compliant vehicles. To secure Aspire Rehab RS, RX & RX JNR wheelchairs, the below steps must be followed:

1. Identify tie down points
(4 in total) on wheelchair.

These are brightly coloured rings (RED or ORANGE) and have TIE DOWN POINT logo stickers on them for easy identification



2. Apply wheelchair brakes
(both sides)

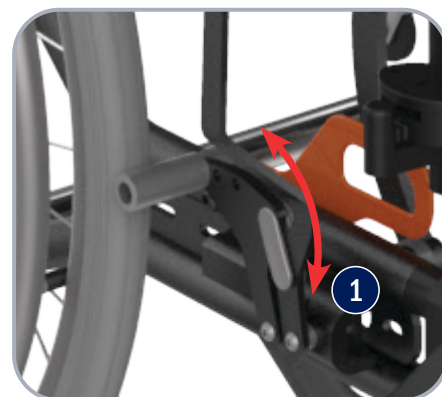

3. Secure all four tie down points ensuring the chair is firmly secured to the vehicle not allowing any movement whilst being transported

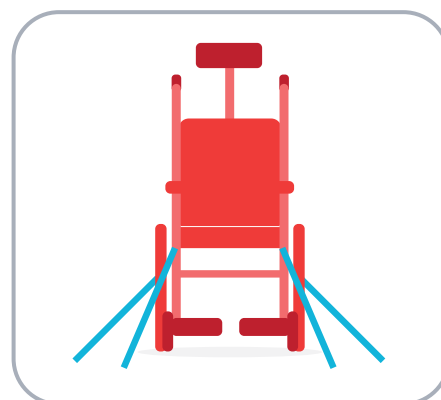

4. Fasten seat belt over the occupants shoulder, passing over their lap, down beside the rear wheel and locking into place in the buckle located on the floor of the vehicle

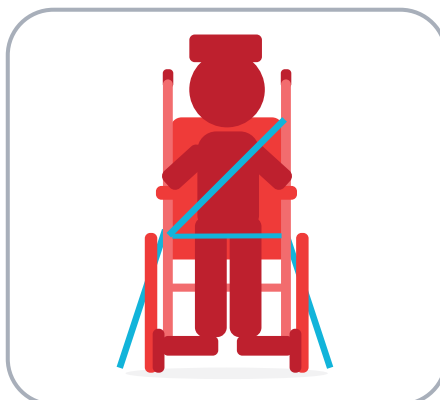



WARNING! DO NOT transport an occupant in the wheelchair if the above process is not correctly followed. It is imperative that these steps are completed in order to ensure occupant safety. The wheelchair is to always be facing the same direction of seats within the vehicle, not to the side or backwards.

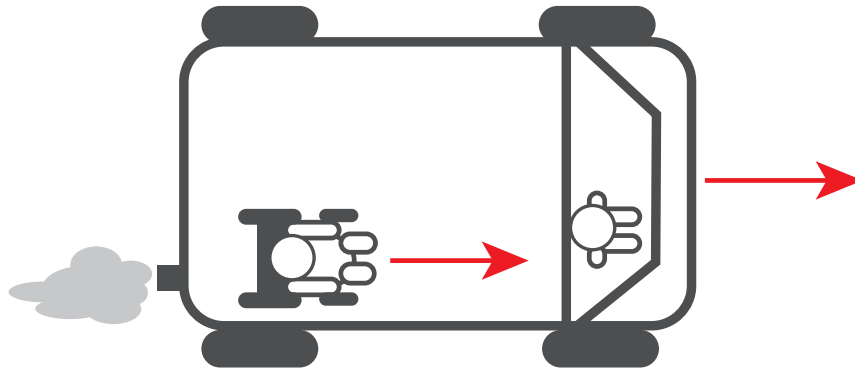

Moving Wheelchair Up a Kerb - With an Attendant

1. Push the wheelchair up to the kerb **FEET FIRST**
2. The attendant should push down on the rear foot peg to slightly incline the chair.
DO NOT tilt the chair back with the push handles
3. Once the front wheels are firmly on the ground above the kerb, the rear wheels should be pushed against the kerb to propel the the entire chair to rest above the kerb



WARNING! This should only ever be done with an attendant and not performed by an occupant on their own. It is very important the above steps are followed to prevent injury to both the occupant and the attendant.

Moving Wheelchair Down a Kerb - With an Attendant

1. Reverse the wheelchair up to the kerb **FEET LAST**
2. The attendant should check for cars or obstructions prior to commencing the descent
3. The attendant should slowly roll the rear wheels down to the road surface, ensuring not to tip the chair
4. Once the rear wheels are firmly on the road surface, the front wheels should be slowly lowered onto the road surface



WARNING! This should only ever be done with an attendant and not performed by an occupant on their own. It is very important the above steps are followed to prevent injury to both the occupant and the attendant.

Using the Wheelchair Brakes (occupant)

Aspire Rehab Tilt in Space Manual Wheelchairs have locking brakes to ensure no movement occurs when the wheelchair is in a stationary position

1. To engage brakes, push forward on the brake lever until firmly locked in place
2. To disengage brakes, pull back on the brake lever until unlocked

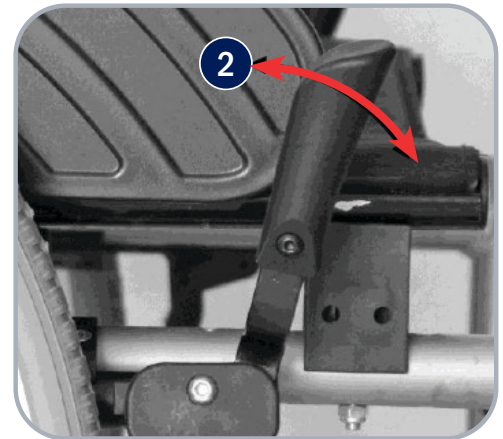
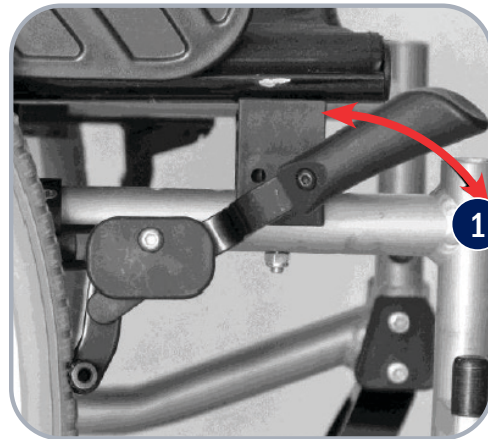

WARNING! Brakes should always be locked when leaving an occupant unattended in the wheelchair.

Using the Wheelchair Brakes (attendant)

Aspire Rehab Tilt in Space Wheelchairs have rear mounted hand brakes to ensure an attendant can control speed and movement when propelling an occupant.

1. To engage brakes, squeeze both hand triggers upwards
2. To disengage brakes, release both hand triggers downwards
3. To secure brakes in place, apply locking lever

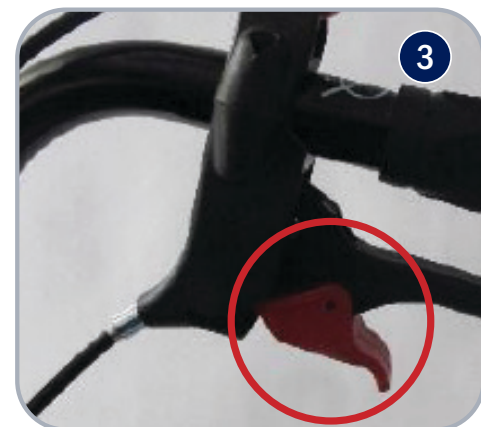

Quick Release Wheels

Rear wheels can be removed easily and without tools to facilitate simple repair and replacement.

1. To detach the rear wheel from the frame, press & hold the release button and remove the wheel from the frame
2. To attach wheel, reverse step 1



WARNING! Ensure quick release axles are mounted correctly and locked in place prior to seating an occupant. It is important to always release the rear wheel brakes prior to trying to activate the release buttons on the rear axles.

9. ADJUSTMENTS

Adjusting Backrest Height

1. Using the allen key supplied, locate and loosen bolts (x4) on the inner section of the backrest frame (2 x each side)
2. Slide the backrest up or down to desired position and fasten bolts to secure backrest into place. To attach wheel, reverse step 1



Adjusting Seat Depth

1. Remove the seat cushion to expose the seating surface
2. Loosen the bolts (x 2) at the rear of the seating surface
3. Underneath the seat frame, loosen the bolts (x 2)
4. Adjust to desired position and fasten all bolts in place (2 x on top of seating surface, 2 x underneath seating surface)

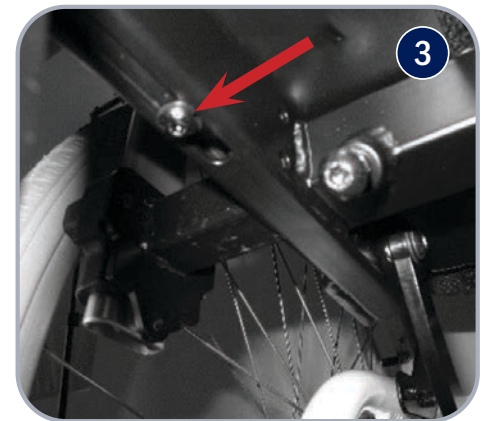
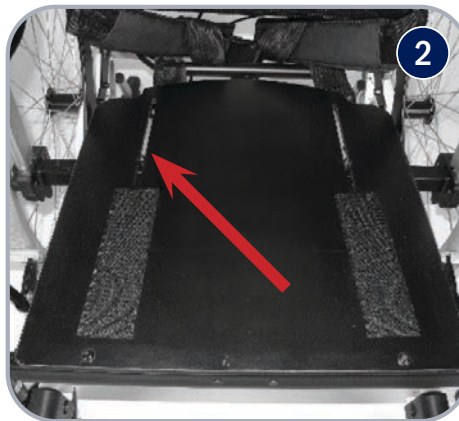

Adjusting Backrest Angle

1. Squeeze left trigger on attendant back cane to enable backrest angle adjustability
2. Hold in and recline/incline until desired positioning is met



Adjusting Tilt in Space (TIS) Angle

1. Squeeze right trigger on attendant back cane to enable tilt in space positioning
2. Hold in and recline/incline until desired positioning is met

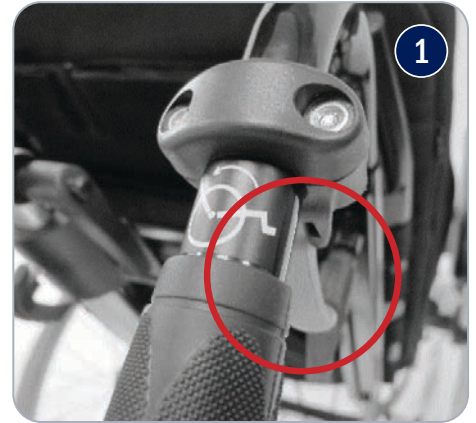

Adjusting Backrest Tension

1. Adjust straps to desired position and reapply upholstery securing in place with velcro

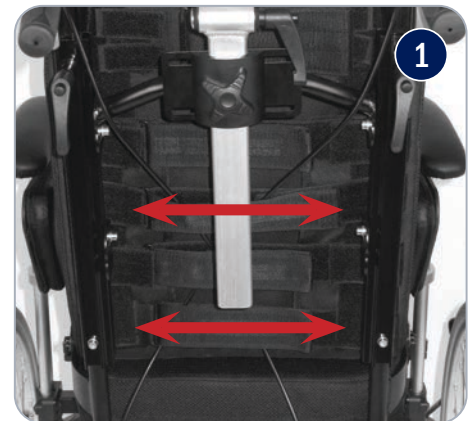

Adjusting Seat Width

1. Armrest mount brackets can be moved to create between 70mm-100mm of seat width adjustment. Removing internal armrest panel padding can create an additional 20mm of seat width.



Adjusting Rear Wheel Axle Height

1. Remove the quick release rear wheel by pressing the black button on the quick release axle, pulling towards you until it is removed
2. Position the axle mount at the desired location and fasten in place. Locate the quick release axle into the axle mount and ensure it has locked in securely before using the wheelchair



NOTE: Ensure the rear wheels are located in symmetrical positions on both sides of the chair to maintain stability.

Adjusting Headrest

1. Adjust height by loosening fastening hand wheel located in the centre of the backrest, fasten in place when desired position is met
2. Adjust angle by loosening lever bolts, fasten in place when desired position is met

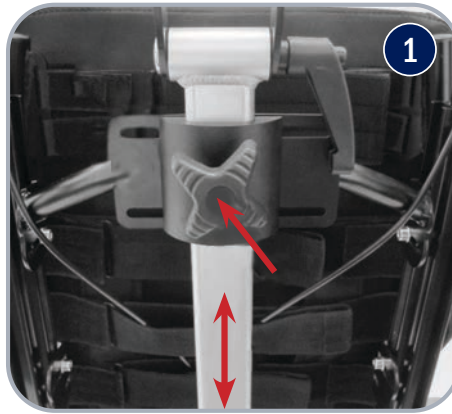

Adjusting Legrest Height

1. Adjust legrest height by unclamping the clamp halfway between the footplate and calf pad mount, lock in place when desired position is located



Adjusting Legrest Angle

1. Adjust legrest angle by pressing the SILVER button on side of legrest, move into desired position and release pressure on button to lock into place



Adjusting Legrest Calf Pad

1. Adjust calf pad angle by unlocking the bolt on the side of the calf pad where it connects to the legrest frame, locate desired position and fasten in place



Adjusting Legrest Footplate

1. Adjust footplate angle by unlocking the bolt on the outer side of the foot plate, fasten in place when desired position is located



Lateral Chest Supports

1. Mount bracket to rear backrest cane, fasten in place with bolts
2. To change the angle, loosen the bolts until desired position is reached, lock in place with bolts

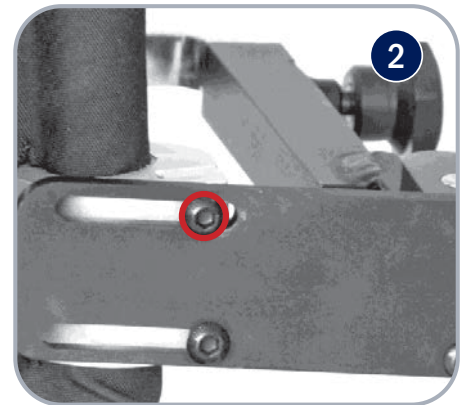
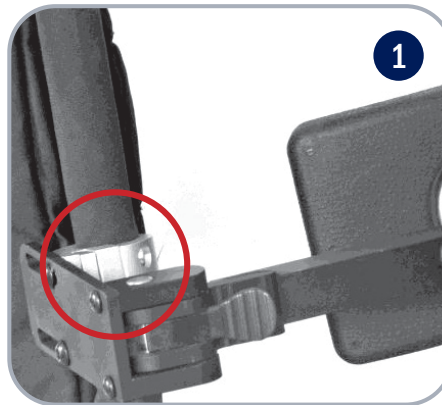

Adjusting Front Fork Height

1. Using the allen key supplied, loosen the bolts and remove the centre pin
2. Reposition to the desired height, reposition centre pin and fasten with bolts



NOTE: Ensure the front castors are located in symmetrical positions on both sides of the chair to maintain stability.

10. ACCESSORIES

Aspire Rehab RS, RX & RX JNR Wheelchairs are compatible with a large range of accessories.

IV Pole

To facilitate Intravenous infusion, IV Poles can be mounted to the wheelchair.

1. The IV pole clamp can be attached to either backrest cane. Once secured firmly in place, drop in the IV pole.

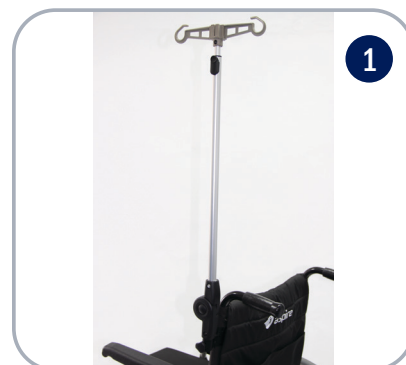

Stump Support

Stump/amputee supports easily bolt onto the frame to ensure amputee occupants can sit in comfort.

1. Insert the stump support into the top of the frame legrest receivers
2. Adjust the height or angle of the stump support by using the hand fastening lever



Lap Belt

For extra safety when manoeuvring an occupant, a lap belt provides extra support to prevent an occupant from falling from a chair.

1. Mount seat belt ends onto either side of the chair and fasten in place with a bolt
2. Lock/unlock lap belt by pressing red centre mount clip



Oxygen Bottle Holder

For occupants who require an oxygen source, the oxygen bottle holder mounts simply to the rear of the chair frame.

1. Align oxygen bottle holder with frame mounting holes and fasten in place with bolts provided
2. Insert oxygen bottle ensuring all tubing and regulator are clear of moving parts, such as rear wheels



Tray Table

An optional tray table is provided for occupants to have meals while being seated on a wheelchair.

1. From the packaging you will receive

- 1 x Tray Table
- 1 x Rod
- 2 x Brackets with 4 x 4mm Screws

2. Use a 3mm and a 4mm hex key to remove screw as indicated on the image.

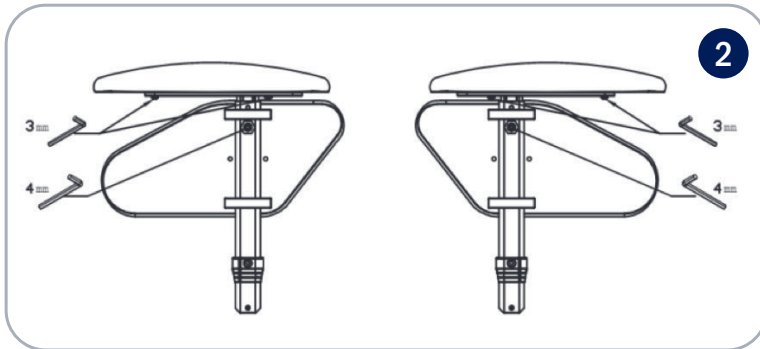
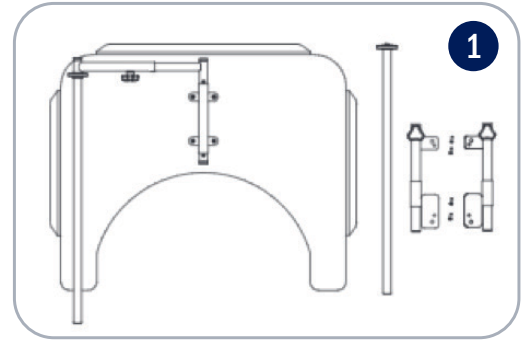

3. Remove the 4 x 3mm screws provided and replace with 4 x 4mm screw with the two brackets (indicated on image 3) provided and attach it in between the armrest and the pads.

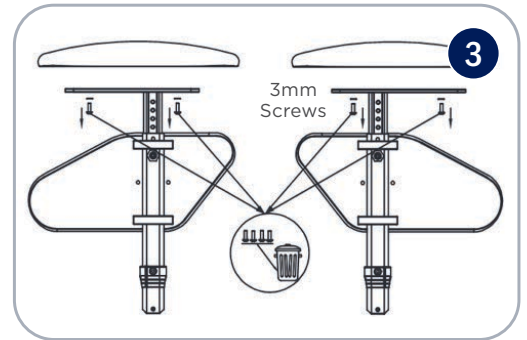

4. Insert the rods into the bracket that has just been attached on the armrest.

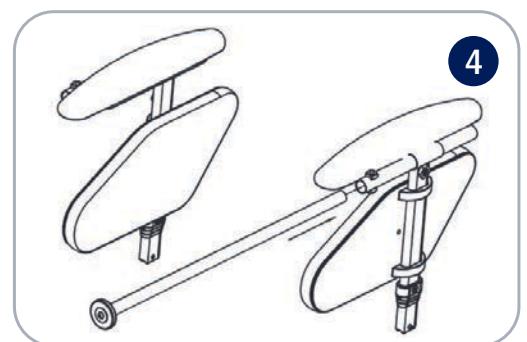
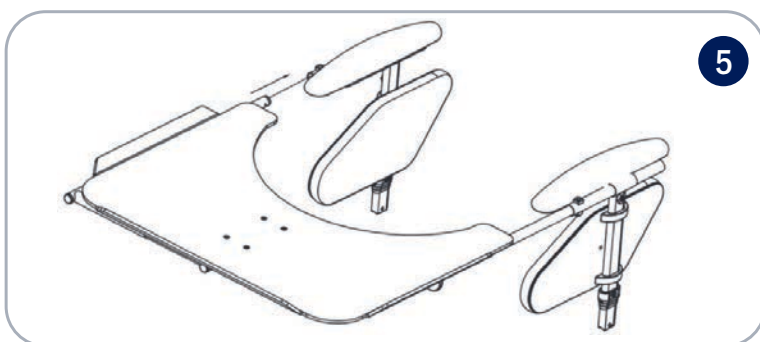
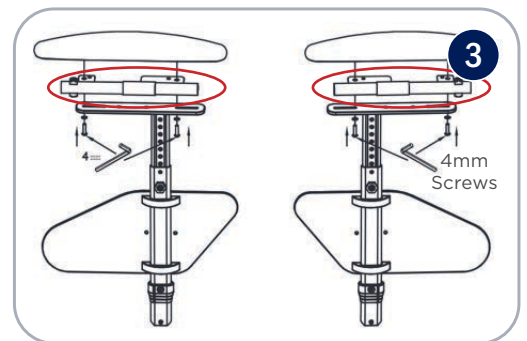

5. Attach the tray table by inserting the tray onto the rods that has been placed on step 4.

6. Use the hand wheel bolts provided on the brackets to lock the tray table on the wheelchair.

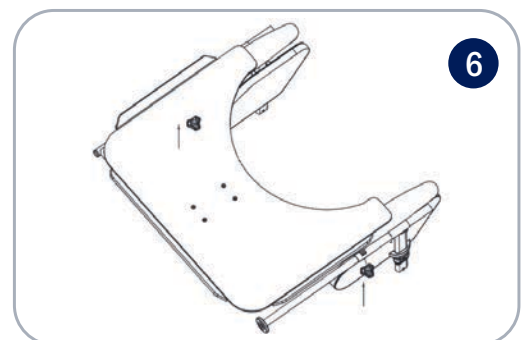

11. TROUBLESHOOTING

<p>Wheelchair is steering/pulling to one side</p>	<ul style="list-style-type: none"> • Make sure the rear wheel axle pins have been inserted correctly • Make sure the end user is able to evenly distribute his/her weight on the wheelchair • Make sure one push rim has not been mounted more tightly than the other • Ensure both front castors forks are adjusted to the same angle at the frame mounts
<p>The wheelchair moves slowly</p>	<ul style="list-style-type: none"> • Ensure rear wheels axle pins have been inserted correctly • Remove any hair or dirt from castor and rear wheel axles • Make sure there is not too much weight applied to the castors, otherwise adjust the centre of gravity • Ensure occupant clothing is not interfering with movement of the rear wheels • Ensure both brakes are disengaged
<p>The wheelchair does not turn smoothly</p>	<ul style="list-style-type: none"> • Make sure the front fork bolts are not over tightened which can restrict front castor wheel rotation • Remove any hair or dirt from castor axles • Ensure both brakes are disengaged
<p>The brakes do not work properly</p>	<ul style="list-style-type: none"> • Check distance between tyres and brake foot is sufficient such that the requisite amount of force can be applied to the tyre surface to stop it moving when the brake is in the engaged position

Correct adjustment of the wheelchair is essential for the successful and safe use of this product.

Should assistance be required, contact the Aidacare Service Department on 1300 133 120.

12. CARE & MAINTENANCE

Maintenance Schedule

Weekly	Periodically	Yearly	Serviceable Components
<ul style="list-style-type: none">• Check brakes are functioning properly	<ul style="list-style-type: none">• Check for signs of wear on front castors• Check for signs of wear on rear tyres	Service to be completed by authorised Aspire service agent	<ul style="list-style-type: none">• Wheels & Tyres• Forks• Axles• Armrest receivers• Cables and Gas Struts• Footrest mounts• Footplates• Armrest Pads

Care for Your Chair

- The seat and backrest cushions can be removed for cleaning. The breathable PU cover can be wiped with a wet sponge and is compatible with Tuffie Wipes provided it is then wiped down with a damp cloth afterwards. All other components can be cleaned with a damp cloth.
- Check tyre condition at least twice per month.
- Check that rear wheel spokes are not loose. Loose wheel spokes can reduce the strength of the rims and must be safely adjusted by a qualified technician.
- Always keep rear wheel quick release axles clean and free from dirt and hair build up.
- Should push rims become scratched these should be de-burred or replaced to avoid damage to skin (not necessary for Aspire Transit 2 model).
- Brakes should be checked regularly.

Should you have any doubts about the correct functioning of the wheelchair or of any of its components, please contact AIDACARE on 1300 133 120 or your local Aspire distributor.

The tool kit provided will allow basic adjustments to the wheelchair, for further information on repairs and service contact AIDACARE on 1300 133 120.

13. WARRANTY

Aspire Rehab Tilt In Space Wheelchairs come with a 2 year warranty on the frame and a 1 year warranty on all components. Please keep purchase invoice as proof of warranty commencement.



Frame



Components

Aidacare is bound by Australian Consumer Law in respect to 'Warranty against Defects' on this product. A copy of the Aidacare 'Warranty against Defects' statement is available upon request. Any contact in regard to warranty matters should be made to Aidacare Customer Service staff on 1300 133 120, emailed to product@aidacare.com.au or communicated directly to your Aspire Dealer.

Aidacare does not warrant against excessive or incorrect use, modification or any situation that could not be deemed as fair wear and tear. Tyres, tubes and castor wheels are not covered under the 2 year warranty as these are considered consumable items. These consumable items carry a 12 month warranty against manufacturer defects only, NOT wear and tear from reasonable use.

The warranty on this product is a back to base warranty and does not cover any freight costs pertaining to the return of any items under warranty. Aidacare acknowledges and conforms to all ACCC guidelines around consumer rights. For further information contact Aidacare 1300 133 120.

Aidacare will not guarantee the safety and the correct functioning of the wheelchair in the case that any of the original components have been changed or modified and or replaced with non-original Aidacare approved parts. If any faults are detected upon receiving the wheelchair please phone Aidacare to arrange a replacement. Any faults that are detected during normal use should be reported to Aidacare immediately to determine if warranty conditions apply and organise repair and/or replacement as applicable.

14. COMPLIANCE

The Aspire Rehab Tilt In Space Wheelchair range is manufactured in ISO compliant production facilities in P.R China to strict quality control standards.

As part of Australian Standards compliance, safety stickers are located on the frame of this wheelchair. Please ensure that you familiarise yourself with these prior to use.

This product complies with Australian Standard AS/NZS 3695.1:2011 and AS/NZS 3696.19. As the importer of this product, Aidacare maintains records of all testing reports and compliance certificates. All testing was Certified by Novitatech Children's Services in South Australia.

Novitatech is an independent NATA accredited laboratory and is widely acknowledged as the leading provider of safety testing services for wheelchairs and mobility products in Australia.

15. SERVICE MAINTENANCE & CUSTOMISATION

FOR ALL ENQUIRIES, PLEASE CALL 1300 133 120

When returning this product for warranty, service or repair work please include all components such as leg rests, armrests and seat cushion. Please ensure wheelchair is clearly marked with owner's name and contact details. Original/copy of original invoice is also required as proof of purchase.

To organise pickup by Aidacare, please call 1300 133 120, standard pickup and delivery charges apply.

SPARE PARTS

Aidacare holds replacement parts for the Aspire wheelchair range. All replacement of parts should be completed by Aidacare or authorised Aspire service technician. The term parts includes but is not limited to: tyres, brakes, armrests, footrests and upholstery.

A complete parts list is available upon request.

CUSTOMISATION AND MODIFICATION

All wheelchair customisation, modifications and or alterations made to this product are considered as "custom" changes. These may cause the product to no longer satisfy Australian Standards and should be considered prior to commencement.

For customisation or modification work, contact AIDACARE on 1300 133 120. Our team of qualified Rehab Engineers are available to assist if required.

16. SERVICE LOG BOOK

YEAR 1 Date: _____

Service Type: _____

Condition Report: _____

Action taken: _____

Inspected By: _____

Signature: _____

YEAR 2 Date: _____

Service Type: _____

Condition Report: _____

Action taken: _____

Inspected By: _____

Signature: _____

YEAR 3 Date: _____

Service Type: _____

Condition Report: _____

Action taken: _____

Inspected By: _____

Signature: _____

YEAR 4 Date: _____

Service Type: _____

Condition Report: _____

Action taken: _____

Inspected By: _____

Signature: _____

YEAR 5 Date: _____

Service Type: _____

Condition Report: _____

Action taken: _____

Inspected By: _____

Signature: _____



Imported by:

AIDACARE P/L | Building 3A, 1 Moorebank Avenue, Moorebank NSW 2170

T - 1300 133 120 | W - www.aidacare.com.au